

***Consortium for
Electric
Reliability
Technology
Solutions***

Real-Time
Voltage Security
Assessment
(RTVSA)

CA ISO Real-Time Voltage Security Assessment Summary Report

**Funded by the
California Public Interest Energy Research
Transmission Research Program**

February 9, 2006

TABLE OF CONTENTS

1	INTRODUCTION	5
1.1	Description of the Voltage Stability Problem	6
1.1.1	Summary of Recommendations by WECC	6
1.1.2	WECC voltage stability criteria	9
1.1.3	System Definitions	10
1.1.4	Representational Issues	10
1.1.5	Modeling Requirements	11
2	OVERVIEW	12
2.1	Prototype Description	12
2.2	Implementation	15
3	SURVEY RESPONSE	16
3.1	Survey Summary	16
3.2	Survey results summary	16
3.3	Minutes of TAC Meetings	16
4	PROPOSED FRAMEWORK	18
4.1	Selected Study Areas	18
4.2	Description of Proposed Framework	18
5	PROTOTYPE RESULTS	20
5.1	Description of the San Diego transmission system	20
5.2	Description of Hyperplane Approximation	23
5.3	On the orientation of 2D hyperplane slices for CHILLS and MSSION	24
5.3.1	Parametric Sensitivities	24
5.3.2	Collapse Participation Factors	26
5.4	On the effects of adding a sink in a congested load pocket	28
5.5	Description of the Humboldt transmission system	29
5.6	Stress Patterns and RTVSA Results for Humboldt	31
5.7	Discussions on Exploring Patterns of Loading	32
6	CONCLUSIONS	33
	REFERENCES	35

TABLE OF FIGURES

Figure 1	Multi-Year Development Roadmap for the CA ISO RTVSA	12
Figure 2	Block Diagram of RTVSA Prototype	13
Figure 3	The proposed integration scheme for the VSA project	14
Figure 4	Predictor-Corrector Algorithm	18
Figure 5	Major Import Paths in the SDGE System.....	20
Figure 6	Map showing the two arms of the SWPL corridor in relation to SDGE	21
Figure 7	Location of Songs and South Bay in the CA EHV Transmission Network	21
Figure 8	One-Lines for the SOBAY-MIGUEL-SONGS area	22
Figure 9	Illustration of Hyperplane Approximation	23
Figure 10	Lagrangian Multipliers for SDGE cases	24
Figure 11	RTVSA Output: Hyperplane slices at Carlton Hills and Mission	25
Figure 12	RTVSA Output: PoC in MW for Carlton Hills and Mission	25
Figure 13	Top Eight Voltage Collapse Participation Factors for Stressing Pattern I.....	26
Figure 14	Top Eight Angle Collapse Participation Factors for Stressing Pattern I.....	26
Figure 15	PV curve for Carlton Hills with Stress Pattern III showing collapse	27
Figure 16	PV curve for Mission with Stress Pattern III showing collapse	27
Figure 17	P Angle curve for Mission with Stress Pattern III showing collapse.....	27
Figure 18	RTVSA Output: Hyperplane slices for Granite and Mission.....	28
Figure 19	Humboldt Area	29
Figure 20	Location of Cottonwood in the CA EHV Transmission Network	29
Figure 21	One Lines for the HUMBOLDT CTTNWD SHASTA area	30
Figure 22	RTVSA Output: Hyperplane slices at Humboldt 1276 and Shasta 2590	32
Figure 23	RTVSA Output: Lagrangian Multipliers for Humboldt	32

TABLE OF TABLES

Table 1	WECC Voltage Stability Requirements	10
Table 2	Bus Index and Color Code for the SOBAY-MIGUEL-SONGS area	22
Table 3	Patterns of SINK PF (Participation Factors).....	24
Table 4	Generator PF at the 3 Units of South Bay (SB) for all Vectors	24
Table 5	Patterns of SINK PF (Participation Factors).....	28
Table 6	List of Humboldt Stressing Patterns.....	31
Table 7	Index for Humboldt Bus Numbers	31

ACKNOWLEDGEMENTS

Special thanks to California ISO engineers Mr. Catalin Micsa and Mr. David Le for their consultations and help with selecting the study areas in California. The project team appreciate contributions from Mr. Sirajul Chowdhury, Mr. Eric Whitley, and Dr. Enamul Haq.

Mr. Dave Hawkins (California ISO) for his expertise, comprehensive support, and advices.

Dr. Yuri V. Makarov (PNNL), project consultant, for his role in suggesting the framework of the project, developing and selecting the methodology, participation in the brainstorm meetings, organizing face-to-face interviews and other contacts with the leading experts, advices, troubleshooting, literature review, and report writing.

Prof. Ian Dobson, (University of Wisconsin-Madison), project consultant, for his role in suggesting and developing the methodology, participation in the brainstorm meetings and interviews, expertise and essential advices.

Dr. S. L. Greene (Price Waterhouse Coopers) for his help with the PSERC software.

Mr. Jim Cole (California Institute for Energy Efficiency) for initiating and support of this project.

Mr. Joseph Eto (Lawrence Berkeley National Lab) for his support.

Participants of the EPG Methodology Survey for their expertise and advices:

- Prof. M. Anantha Pai (University of California – Berkeley)
- Mr. Raymond L. Vice (Southern Company Services, Inc.)
- Dr. Savu Savulescu (Energy Concepts International Corp.)
- Dr. Michael Y. Vaiman and Mrs. Marianna Vaiman (V&R Energy Systems Research)
- Dr. Alex M. Kontorovich (Israel)
- Dr. Anatoliy Meklin (Pacific Gas and Electric)
- Prof. Marija D. Ilic (Carnegie Mellon University)
- Prof. Enrico De Tuglie (Politecnico di Bari, Italy)
- Prof. Gerald T. Heydt (Arizona State University)
- Mr. William Mittelstadt (Bonneville Power Administration)
- Prof. Yixin Yu (Tianjin University, China)
- Mr. Carson W. Taylor (Bonneville Power Administration)
- Prof. H.-D. Chiang (Cornell University)
- Dr. Navin Bhatt (American Electric Power)

Participants of the face-to-face interviews for their evaluation of the project and advices:

- Prof. Ian Dobson (University of Wisconsin – Madison)
- Prof. Vijay Vittal (Arizona State University)
- Prof. Venkataramana Ajjrapu (Iowa State University)
- Dr. Zhao Yang Dong (University of Queensland, Australia)
- Dr. Anatoliy Meklin (Pacific Gas and Electric)
- Dr. Vitaliy Faybisovich (South California Edison)
- Dr. Michael Vaiman and Dr. Marianna Vaiman (V&R Energy Systems Research)

Participants of the TAC Meetings:

- Dr. Jim Gronquist (Bonneville Power Administration)
- Dr. Steve Lee (Electric Power Research Institute)

1 INTRODUCTION

The Voltage Security Assessment (VSA) project is designed to be part of the suite of advanced computational tools for congestion management that is slated for practical applications in California in the next few years. Modern voltage assessment methods include the development of such advanced functions as identification of weak elements, automatic selection of remedial actions and automatic development of composite operating nomograms and security regions. Real-time production-grade VSA tools are becoming increasingly available nowadays. These tools are integrated with EMS/SCADA systems and use results from the state estimator.

Some advanced contemporary real-time applications already promote the idea of using the security regions determined in parameter space with the composite boundaries limited by stability, thermal, and voltage constraints. At the same time, the majority of the tools are still based on the static system power flow models and implement such traditional approaches as sink-source system stressing approach, P-V and V-Q analyses, V-Q sensitivity and modal analysis. Unfortunately, many of the most promising methods suggested in the literature have not been implemented yet in the industrial environment, including the state-of-the-art direct method to finding the exact Point of Collapse. Currently there exists no real-time monitoring tool for voltage security assessment. The problems of voltage security will be exacerbated by the effects of multi-transfers through the network. These sets of simultaneous transfers are manifest because of the buying and selling of electric power across the boundaries of control areas. Moreover the point of production and the point of delivery may be in geographically distant locations.

An extensive analysis of existing VSA approaches was conducted. This included research by EPG, surveys from the leading experts' opinion worldwide, feedback from industrial advisors and brainstorm meetings with the projects' consultants. A state-of-the-art combination of approaches and computational engines was identified and selected for implementation in this project. The suggested approach is based on the following principles and algorithms:

- Use the concepts of local voltage problem areas and descriptive variables influencing the voltage stability problem in each area. Utilize information about the known voltage problem areas and develop formal screening procedures to periodically discover new potential problem areas and their description parameters.
- Calculate and approximate the voltage stability boundary off real time, and apply the approximated voltage security conditions in real time for a fast VSA. Use hyperplanes to approximate the voltage stability boundary.
- Apply the dual space concept while developing the sets of approximating hyperplanes. Use the descriptive variable space to determine the sequence of stress directions to approximate and visualize the boundary. Perform all the rest of the required computational work in the parameter space. A mapping between the dual spaces can be established based on pre-determined generation dispatches and load scaling patterns and linearization.
- To calculate the approximating hyperplanes, apply a combination of the parameter continuation techniques and direct methods as suggested in this report. Introduce a sufficient additional security margin to account for inaccuracies of approximation and uncertainties of the power flow parameters.
- Produce a list of abnormal reductions in nodal voltages and highlight the elements and regions most affected by potential voltage problems. The list of most congested corridors in the system will be ranked by the worst-case contingencies leading to voltage collapse.

The initial framework of this project was originally formulated by California ISO. The key elements of the suggested approach which are the use of parameter continuation, direct methods and the hyperplane approximation of the voltage stability boundary were approved by a panel of leading experts in the area in the course of a survey conducted by EPG in 2005. These concepts were also verified in the course of face-to-face personal meetings with well-known university

professors, industry experts, software developers and included email discussions and telephone exchanges. CERTS industrial advisors approved these developments during two TAC meetings conducted in 2005.

In 2005, the project development team successfully implemented the parameter continuation predictor-corrector methods. Necessary improvements were identified and developed. The PSERC parameter continuation program and MATLAB programming language were used in the project. The techniques were tested for the California San Diego problem areas suggested for these purposes by California ISO. The approximated voltage stability boundary was compared to the results obtained from the GE PSLF program commonly used in the Western Interconnection.

Work in future years will include Direct Methods and the investigation of descriptive variables. This will further develop the concept of utilizing the dual space approach to choose axis sets that are needed for visualization purposes. Direct Method algorithms will be developed for finding the exact PoC (Point of Collapse). In addition, procedures will be implemented for selecting the minimum number of approximating hyperplanes. Other items in the scope of future work are techniques for analyzing margin sensitivities, coping with parameter uncertainties, and selecting remedial actions. The prototype tool will be tested for some additional problem areas in California, and then expanded to the entire CA ISO system.

1.1 Description of the Voltage Stability Problem

A system enters a state of voltage instability when a disturbance, increase in load demand, or change in system condition causes a progressive and uncontrollable decline in voltage. The main factor causing voltage instability is the inability of the power system to meet the demand for reactive power. *Voltage stability* is the ability of a power system to maintain acceptable voltages at all buses in the system under normal operating conditions and after being subjected to a disturbance. *Voltage stability margin* is the distance to instability determined for a selected *loading* or *stress direction* in parameter space. It is known that voltage magnitudes alone are poor indicators of voltage stability or security. Voltages can be near normal with generators, synchronous condensers, and SVCs near current limiting levels, thus resulting in a possible voltage collapse. Therefore, it is prudent to specify a MVAR margin or MW margin [20].

Venikov and co-authors in [41] first demonstrated that under certain model assumptions, such as constant voltages of the generator buses, matching load models and the same slack bus model, the static aperiodic stability limit or the saddle node bifurcation coincides with the power flow feasibility limit. This allows analyzing aperiodic stability limits using conventional power flow models under these modeling assumptions. Generally speaking, for the voltage stability problem, the assumptions do not hold, but nevertheless, the power flow model, and the power flow Jacobian matrix singularities are frequently used for an approximate description of the static aperiodic voltage stability problem.

1.1.1 Summary of Recommendations by WECC

The following is a list of blackouts and near blackouts related to voltage collapse. Many system blackouts and “near misses” were related to voltage instability and voltage collapse problems. See [1] to [19] for more details and among these, the following major events can be mentioned.

1. 1965: Eastern US and Canada
2. 1970: Japan and New York Power Pool
3. 1977: New York City and Jacksonville, Florida
4. 1978: France
5. 1982: Belgium and Florida
6. 1983: Sweden

7. 1987: Tokyo, Japan, Western Tennessee, France
8. 1989, 1993-1994: Italy
9. 1996: US Western Interconnection (2 events)
10. 1997: The Netherlands
11. 1998: Atlanta, San Francisco Area, Upper Midwest U.S.
12. 1999: Northeast U.S. (2 events)
13. 2003: Croatia and Bosnia Herzegovina, Eastern U.S. and Canada, Denmark and Sweden, and Italy
14. 2004: Western Norway and Southern Greece
15. 2005: Moscow region, Russia

These also include the following blackouts or “near blackouts” related to voltage collapse:

1. Severe blackout in Eastern US (including NYC) and Canada on November 9, 1965 was initiated by disconnection of one of the five 230-kV lines from Beck power plant going north to Toronto. The blackout affected ~30 million people in Canada and USA, including New York City and lasted 13 hours. [2,3]
2. New York Power Pool disturbances of September 22, 1970. [1,18]
3. New York City blackout on July 13, 1977 was caused by a thunderstorm and heavy winds and rain. It affected 3 million people and lasted 22 hours. [2,3]
4. Jacksonville, Florida on September 22, 1977.
5. France December 19, 1978 [1,19].
6. Northern Belgium, August 4, 1982 [1,19].
7. Florida, September 9, November 26, December 28 and 30, 1982.[1,18]
8. Voltage collapse in Sweden on December 27, 1983, was a result of a breaker failure at a 400 kV substation. The blackout affected 4.5 million people and lasted 5.5 hours. [1,2,4]
9. Tokyo, Japan, July 23, 1987 [1,5]
10. Western Tennessee, USA, August 22, 1987 [6]
11. France, January 12, 1987 [1,19].
12. Italy, 1989.
13. Italy, 1993 and 1994.
14. US Western Interconnection Blackout, July 2, 1996, started with loss of two 345 kV transmission lines Jim Bridger – Kinport and subsequent tripping of two Jim Bridger units in the southern Idaho-Montana region. This initiated a blackout in 14 western states, two Canadian provinces, and the northern portion of Baja California, Mexico. [7]
15. US Western Interconnection Blackout on August 10, 1996. This disturbance effectively began with the loss of the Keeler-Allston 500 kV line in the Portland area. WECC system was separated into four islands, interrupting service to 7.5 million customers for periods ranging from several minutes to about nine hours. [8]
16. The Netherlands, 1997.
17. Atlanta, a near blackout situation with prolonged voltage reductions to 0.95 p.u., on June 2, 1998.
18. California ISO system disturbance (in San Francisco Area), December 8, 1998. The disturbance was caused by a PG&E construction crew and by the Substation

Operators failing to follow standard procedures at San Mateo substation. The blackout affected more than 456,000 customers and nearly one million people. [9]

19. Upper Midwest Blackout on June 25, 1998 load and affected 152,000 people in Minnesota, Montana, North Dakota, South Dakota, and Wisconsin in the United States; and Ontario, Manitoba, and Saskatchewan in Canada. Outages lasted up to 19 hours. The blackout was initiated by a lightning storm in Minnesota [3]
20. Northeast U.S. non-outage Disturbances on July 6 and 19, 1999, were caused by above-expected load in the PJM system. A near blackout situation with prolonged voltage reductions to 0.95 p.u. A voltage collapse was barely averted through the use of emergency procedures. [3]
21. Blackout in Croatia and Bosnia Herzegovina on January 12, 2003 was triggered by a short-circuit and circuit breaker malfunction on the 400 kV transmission line Konjsko – Velebit. [10]
22. Blackout in the Eastern U.S. and Canada, August 14, 2003, was initiated by subsequent tree contacts of sagging conductors on the Stuart-Atlanta, Harding-Chamberlin, Hanna-Juniper, and Star – South Canton 345-kV transmission lines. The blackout affected up to 50 million people and caused shutdowns of more than 250 power plants with the total generation capacity loss reaching 61,800 MW. The estimated economic damage was \$4.5-\$10 billion. [3,12]
23. Denmark and Sweden, September 23, 2003, was caused by a short-circuit that affected two busbar sections at the Horred 400 kV substation in western Sweden. About 2.4 million people were left without electricity for several hours. [12,13]
24. Italy, September 28, 2003 was triggered by tree flashover of the 380 kV transmission lines Mettlen – Lavorgo and Sils – Soazza (in Switzerland). 57 million people were affected, restoration took about 4 hours. [14,15]
25. Western Norway, February 13, 2004. The blackout was caused by tripping the Nesflaten – Sauda 300 kV line and malfunctions of the distant fault protection system. This 0.5 hours affected almost 500,000 people. [4]
26. Southern Greece and Athens blackout on July 12, 2004 was caused by the loss of unit 2 (300 MW) at the Lavrio power station in the Athens area. [16]
27. May 24-25, 2005, Blackout on the Moscow region, Russia was caused by a combination of factors including severe equipment damages at the Chagino substation, short-circuits due to sagging of overheated conductors on the 110 and 220 kV lines, reactive power shortage and voltage decline in the southern part of the Moscow Power System, and others. The Moscow blackout left at least 4 million people without electricity supply for more than 24 hours. [17]

Analysis of these blackouts indicated a need in developing real-time tools for monitoring system security margins including voltage stability margins under the normal and contingency conditions.

In connection to the June 2-3, 1996, major blackout in the WECC system, the Department of Energy recommended, among the others, the following measures to be implemented by WECC members to prevent future voltage collapse incidents [7] “WECC shall review the need for a security monitor function in the Western Interconnection to monitor operating conditions on a regional scale. WECC shall review the need for tools such as on-line power flow and stability programs and real time data monitors that can assess primary reliability indicators for frequency and voltage performance system-wide on a real-time”.

These tools should have a look-ahead capability to leave time for real-time dispatchers to recognize the situation and apply preventive remedial actions. On October 18, 1996, the WECC investigation team analyzing August 10, 1996, blackout strongly recommended the following

measure [8] “WECC shall pursue implementation of on-line power flow and security analysis, and recommend appropriate actions to increase the monitoring of key system parameters that would allow operators to identify potential problem outages and take corrective actions”. Similar recommendations were formulated by the analytical teams investigating voltage collapse related blackouts in the other countries.

Summarizing the outcome of the previous blackout investigations, the U.S.-Canada Power System Outage Task Force that conducted the analysis of the August 14, 2003, blackout reiterated that “The current processes for assessing the potential for voltage instability and the need to enhance the existing operator training programs, operational tools, and annual technical assessments should be reviewed to improve the ability to predict future voltage stability problems prior to their occurrence, and to mitigate the potential for adverse effects on a regional scale”. The Task Force also indicated that the blackout on August 14, 2003, had several causes or contributory factors in common with the earlier outages, including:

- *Failure to ensure operation within secure limits*
- *Failure to identify emergency conditions and communicate that status to neighboring systems*
- *Inadequate regional-scale visibility over the power system*

Despite the long history of similar requests to develop real time dispatcher tools to monitor the available voltage security, voltage stability and reactive power margins, those recommendations are not completely met by the majority of the US power system control centers. The CERTS survey [20] revealed that the “voltage collapse issues were only evaluated when the full AC power flow indicated an unusual operating condition, such as questionable voltage profiles. When voltage collapse or transient stability problems were suspected, the analysis was transferred to operations planners for detailed analysis. Some operators were guided by seasonal nomograms. In some cases this lack of dynamic security analysis activity was due to a lack of problems, or of interest in these phenomena. In other cases, it was due to a lack of efficient and integrated tools”.

Besides the dispatchers’ situation awareness and advisory purposes, there is a potential to develop automatic systems to prevent voltage instability and restore depressed voltages in the grid. This opportunity becomes especially important when the voltage collapse development process does not leave the human dispatchers to recognize the situation and apply adequate control measures. Controllable system separation could prevent a widespread system failure. Such a challenging task may be targeted by future R&D projects.

1.1.2 WECC voltage stability criteria

The WECC voltage stability criteria [20], [24] are specified as real and reactive power margins and are apparently oriented mainly to the offline studies. At a minimum, each WECC member system shall conduct P-V and V-Q analyses to ensure that the minimum required margins are met. Sole reliance on either P-V or V-Q analysis is considered as not sufficient to assess voltage stability and proximity to voltage collapse. Each analysis is needed to confirm the results of the other. P-V analysis is needed to confirm the results of V-Q analysis.

Member systems may use either method for general voltage stability evaluation and contingency screening. However, voltage stability margins must be demonstrated by both P-V and V-Q analyses. Table 1 lists the voltage stability criteria and the minimum margins for each disturbance level specified in [27]. From Table 1, the performance level “A” margin requirement is 5%, decreasing by one half for subsequent performance levels “B” and “C”.

The percent quantity refers to the point of collapse value of the loading parameter in a given study. Thus, if the study considers a transfer across a key interface, then it is the percent of that flow that establishes the margin.

Performance Level	Disturbance: - Fault or No Fault - DC Disturbance	MW Margin	MVAR Margin
A	Any element such as: One Generator One Circuit One Transformer One reactive Power Source One DC Monopole	$\geq 5\%$	Worst Case Scenario
B	Bus Section	$\geq 2.5\%$	50% of Margin Requirement in Level A
C	Any combination of two elements such as: A Line and a Generator A Line and a Reactive Power Source Two Generators Two Circuits Two Transformers Two Reactive Power Sources DC Bipole	$\geq 2.5\%$	50% of Margin Requirement in Level A
D	Any combination of three or more elements such as: Three or More Circuits on ROW Entire Substation Entire Plant Including Switchyard	> 0	> 0

Table 1 WECC Voltage Stability Requirements

1.1.3 System Definitions

Voltage collapse is the process or sequence of events accompanying voltage instability that leads to unacceptable voltage profiles in a significant part of the system [1]. Many voltage collapses are not concentrated in a few power system buses. Rather the collapse is regional or involves the entire system. Utilities spend considerable resources in assembling sets of patterns of loading that the power system could actually experience in the next few hours. The ability of VSA to predict voltage profiles will benefit utilities by pruning the worst-case patterns of loading.

The power flow problem is described by a set of nonlinear algebraic equations that are generally different compared to the set of nonlinear algebraic equations obtained from the differential equations and describing the static voltage stability phenomena. The power flow calculations normally use simplified component models and involve secondary control models such as generation dispatch, multi-area power flow and switching capacitors. At the same time, while varying power flow parameters, the power flow equations may become inconsistent, and because of this a physical power flow solution ceases to exist. Such situations correspond to the *power flow feasibility limits* or *power transfer limits*. The power flow feasibility limit is determined by points where the power flow Jacobian matrix¹ becomes singular or has a zero eigenvalue, or has a zero determinant, or can be nullified by multiplying by a nonzero vector.

1.1.4 Representational Issues

The number and selection of states in the system state vector allow a complete description of the dynamical behavior of the system. If the system has only three states, then the state vector has three components and can be visualized as a point in three-dimensional space, and the state space is three-dimensional. A similar concept applies when there are more than three states, say n states. The state vector is thought of a point in an n -dimensional state space. An example of

¹ The Jacobian matrix of a set of n equations in n variables is an $n \times n$ matrix of partial derivatives whose entries are the derivatives of each equation with respect to each variable [31].

state space is the space of nodal voltage magnitudes and angles [31]. The parameter space can include any parameters that influence voltage stability. One of the examples of parameter space is the space of nodal active and reactive power injections, such as loads and generation. A system operating point can be represented both in state space and parameter space.

Power Injection Space: A representation of the Point of Collapse boundary can include co-ordinates of voltage magnitudes, voltage angles, real power injections and reactive power injections. These co-ordinates are indexed by buses. The bus power injections completely specify the power system state via the power system static equations. The various limits on power system operation can therefore be specified in power injection space. The position of the power injections of an operating point relative to these limits gives a representation of the power system security that is complete in the sense that all other representations of the power system security can be computed from it. It is also natural to use power injection space to specify transfers, load changes, redispatch, VAR support, generator and line flow limits. This justifies the basic hyperplane representation of the Point of Collapse boundary in power injection space.

Descriptive Variable Space : It is often useful to augment the set of power injections with other parameters. Then the hyperplanes in the augmented space indicate how the power injection hyperplanes change with parameters. This is used to compute the variation or sensitivity of the hyperplanes to input data and control parameters. Augmentation with states such as voltage angles and magnitudes gives a space containing both parameters and states and corresponding hyperplanes. The co-ordinates used in such a hyperplane representation of the Point of Collapse boundary have been named descriptive variables. Descriptive variables are usually a set of parameters describing cutset flows or flowgate flows. More generally, descriptive variables can be regarded as sets in parameter/state space of interest that are incomplete in the sense that these sets do not completely specify the power system state. For example, interarea flows are descriptive variables. In the simplest of cases, these descriptive variables may be linear combinations of the co-ordinates that are available at each bus. There are more complicated representations of these co-ordinates in which the power injections may be mapped to descriptive variables in a fashion that is not one-to-one. The descriptive variables are typically much fewer than the parameters, so many different parameters sets are mapped to a smaller set of descriptive variables. For example, if the descriptive variables are selected cutset flows, then many different sets of power injections yield the same cutset flows.

1.1.5 Modeling Requirements

The complete understanding of voltage collapse [31] requires a dynamic model in order to explain why the voltages fall dynamically. However, some computations concerning voltage collapse require only a static model. If a dynamic model is required, the power system is modeled by a set of differential equations with a slowly changing parameter. Computations which only require static models are advantageous because the results do not require load dynamics and other dynamics to be known. When using static models to obtain practical results, there is a caveat that there must be a way of identifying the stable operating equilibrium of the power system. In principle, this requires a dynamic model, but the stable operating point is often known by observing the real power system, or by experience, or by knowing the stable operating equilibrium at lower loading and tracking this equilibrium by gradually increasing the loading. Computations associated with voltage collapse that require dynamic models include (a) predictions of the outcome of the dynamic collapse, (b) any problem involving significant step changes in states or parameters, (c) any computations involving eigenvalues or singular values away from the voltage collapse.

2 OVERVIEW

2.1 Prototype Description

The purpose of this section is to provide a description of the RTVSA prototype tool and demonstrate how the prototype tool captures the main functionalities of the VSA project and helps its implementation. The Electric Power Group in cooperation with CA ISO, ENERGY COMMISSION, and LBNL has developed a Multi-Year Development Roadmap for the VSA project shown in Figure 1. The roadmap consists of three task tracks including data requirements, algorithms and prototype development. It is systemized in four phases starting from the current phase 2.

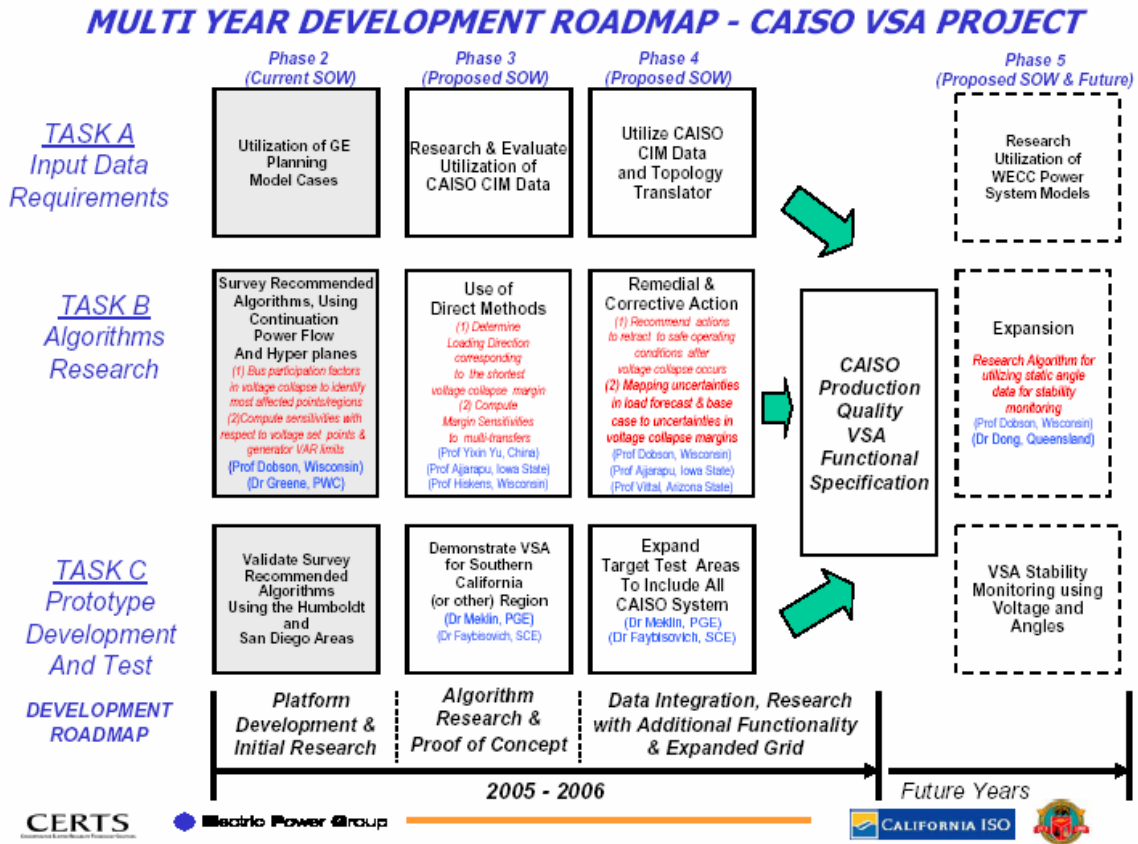

Figure 1 Multi-Year Development Roadmap for the CA ISO RTVSA

The phases include platform development and initial research, algorithm development and the proof-of-concept simulations, and data integration and project expansion. The project time span is two years with the potential expansion for the future years. For each track and each phase, the tasks are formulated, and the suggested project support teams are provided. The original VSA Prototype Functional Specification Summary is described by Figure 2.

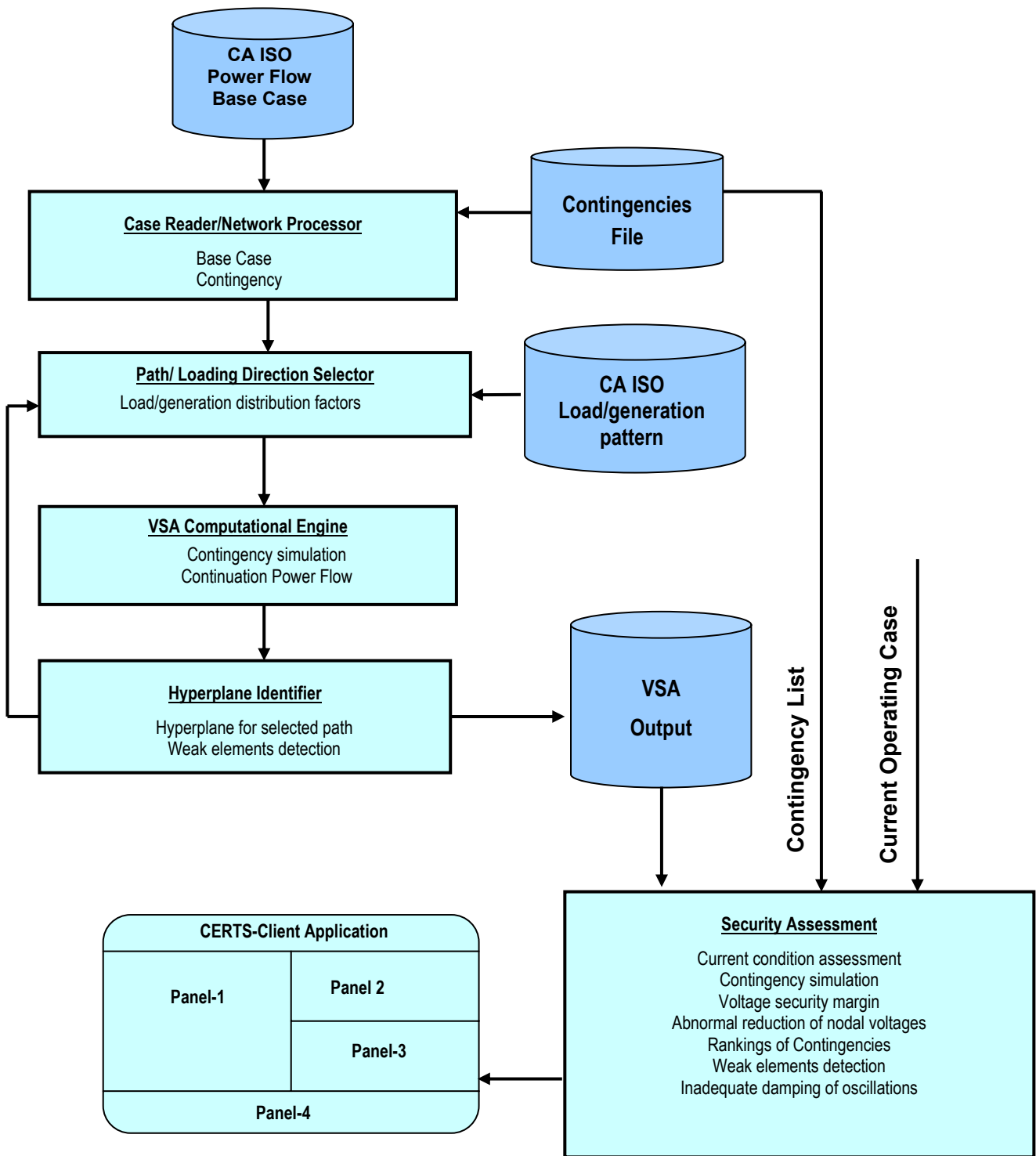

Figure 2 Block Diagram of RTVSA Prototype

What Will The VSA Application Do?

The *VSA application under development* will be linked to the CA ISO EMS system model and data, develop and approximate voltage security regions, which is a form of multi-dimensional nomograms, using hyperplanes, calculate voltage stability indices and identify and display abnormal low voltages and weak elements and places in the system most vulnerable to voltage and voltage stability related problems. This application will also perform contingency analysis and provide the system operators with the voltage problem contingency rankings for the purposes of system monitoring and selecting preventing and emergency corrective actions. This application will be running in real time with the five-minute periodicity and provide the look-ahead capability, for up to two hours ahead, to allow the dispatchers to evaluate the situation, select and apply adequate remedial actions.

The *prototype tool will* implement, test and demonstrate the key elements of the future industrial grade VSA tool. The key elements of the prototype are described below in Figure 3.

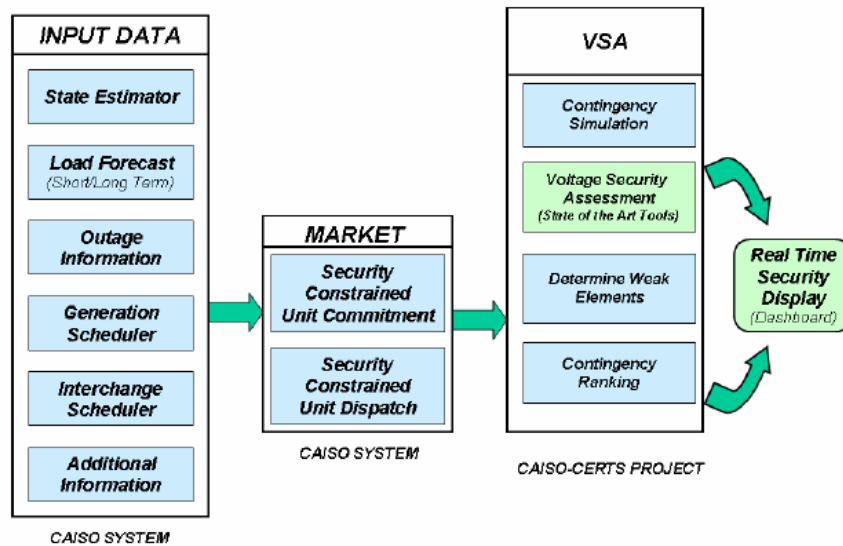

Figure 3 The proposed integration scheme for the VSA project

Project grid monitoring visualization solution

The VSA application will be designed for use by the CA ISO operators in monitoring and predicting system performance two hours ahead. EPG will work with the CA ISO to design a data display format suitable to CA ISO operators. The real time display will have the following information:

- The current operating condition
- Contingencies with insufficient stability margin
- Contingency ranks based on severity indices
- Abnormal reductions of nodal voltages
- Voltage security margins

2.2 Implementation

The project was split into 3 tracks and these tracks were further subdivided into yearly goals (see Figure 1). The end product of these set of goals will be a phased implementation for the complete functional specifications for a production quality VSA system based on the results and benchmarking abilities of the prototype developed in concert with external advisors. Some of the items below have already been completed in 2005.

- Conduct an extensive review of the existing methods, algorithms, and production-grade VSA tools on the global scale, analyze the evolution and competition of the ideas in the area, identify the most promising proven approaches, and based on this analysis select state-of-the-art methods and algorithms for this project.
- Review the voltage collapse blackouts for the last 40 years and summarize relevant recommendations of the blackout investigation teams.
- Contact the leading experts in the VSA area worldwide and conduct a survey summarizing their collective opinion on the selected candidate approaches; modify the selected framework based on the expert feedback. Present and discuss the project at the industrial and CERTS advisory meetings. Organize a series of face-to-face interviews and brainstorm meetings with the University professors, project consultants, CA ISO staff and utility engineers engaged in the area, Identify a group of potential contributors for the project. Cooperate with the other CERTS members and PSERC in order make this project successful.
- Work out a step-by-step design of the project based on the selected state-of-the-art algorithms. Develop new approaches whenever it is necessary. Evaluate, test and select the existing software tools that can be incorporated in the prototype software.
- In cooperation with the CA ISO personnel, select areas with the known voltage stability related problems, design and conduct verification procedures for the prototype tool using the standard power flow computation tools such as PSLF.
- Develop design specification and produce a comprehensive report.
- Pre-calculation and approximation of the voltage stability boundary in the off-line mode
- Calculation of the voltage stability margin in real time using the pre-calculated approximations of the voltage stability boundary
- Identification of abnormal reductions of nodal voltages, weak elements and regions most affected by voltage and voltage stability problems.
- Transfer the conceptual design to CA ISO, other California Control Areas and Utilities and to the Vendors selected by these organizations for the further implementation of the design as production-grade operating tools.
- Cooperate with CA ISO-selected vendor in development of the production-quality VSA.

3 SURVEY RESPONSE

The formulation of the CA ISO sponsored survey that inquired about the existing state-of-the-art algorithms for VSA from among experts in the industry and in the universities will be described. Further individual feedback from experts who had responded were obtained. These were tabled at the Technical Advisory Committee (TAC) Meeting in Pasadena on February 25, 2005. The Survey, the Survey Results and the TAC Meeting Minutes will be summarized.

3.1 Survey Summary

A survey was sent to experts in the power system field for comments, information, suggestions, and recommendations on the algorithms and methodologies for a state-of-the-art RTVSA application. The California Independent System Operator (CA ISO) and other Grid and Transmission System Operators in California need such a tool to explore avenues to better optimize utilization of the existing transmission system via development of state-of-the-art real time wide-area security assessment applications.

3.2 Survey results summary

CERTS/EPG formulated a survey to reach out to experts in this field for comments, information, suggestions, and recommendations related to the VSA project.

Survey Overview. The survey was sent to 51 experts in universities and in the power industry worldwide. Sixteen reviewers responded. Eight of these respondents are from the power industry and eight are from academia.

Summary of Responses. The consensus opinion was that the hyperplane approximation approach is well suited for VSA. Voltage instability is more of a local area/region phenomenon. Some participants felt that time domain simulations should augment the direct methods. One participant from the industry mentioned that it was not clear how switching conditions could be revealed without time domain simulations. Another respondent from the industry shared his difficulties with developing suitable VSA metrics because of the presence of both continuous, such as load growth and non-continuous, such as contingency, factors.

Main conclusions. The majority of responses favored the use of the hyperplane approach in determining voltage security assessment. Also, the majority of responses did not see hyperplanes suitable for determining dynamic voltage assessment at this time.

Recommendations.

- Use the hyperplane approach to approximate security regions for the VSA purposes.
- The computational engine for the VSA project is recommended to be the continuation power flow. This tool has been tested and proven by several researchers in commercial and non-commercial software.
- Pursue a hybrid approach, where the direct method is used for fine-tuning the security boundaries after an iterative set of continuation power flows.

3.3 Minutes of TAC Meetings

February 25, 2005, CERTS Technical Advisory Committee Meeting.

The CERTS TAC meeting in October was attended by the following technical advisors: Ian Dobson (University of Wisconsin-Madison, PSERC), Joe Eto (LBNL), Bernie Lesieutre (LBNL), Yuri Makarov (CA ISO), Jim Dyer (EPG), Manu Parashar (EPG), Carlos Martinez (EPG), Matthew Varghese (EPG) and Jim Cole (CIEE). The following recommendations and comments were made by the Advisors:

- The overall consensus was that the hyperplane approach was well suited for VSA
- It was agreed that the security boundaries are intended to be defined offline with the possibility of extending this to online if found feasible

- Existing nomograms could be improved by the VSA results
- Some filtering scheme would be required to ignore known weak elements/points in the system which aren't of concern, such as low voltage areas and radial networks.
- The general consensus was that transient stability assessment was infeasible at this time. Concerns were expressed that the real-time transient analysis is not practical with the current dynamic models.
- The next steps of the plan should include:
 - Share the feedback received with those who provided input
 - Utilize the experience of expert advisors during the project development, such as Prof. Ian Dobson (University of Wisconsin) and Dr. Anatoliy Meklin (PG&E)
 - Develop a detailed project plan, including the necessary methods of evaluating and testing the various functionality of this application
 - Develop a detailed functional specification to include description of the overall process of how the VSA will integrate and work with CA MRTU and ADS systems.
 - We should quickly move to evaluate the types of power flows needed, such as continuation power flows. Run simulations to find critical points.
 - Document planned development for the near future.
- Jim Cole encouraged the group to investigate ways in which these projects can be related to congestion reduction. Congestion management costs the CA ISO some 500 million dollars and any project that helps reduce this congestion by 10% will be very appealing.

October 16, 2005, CERTS Technical Advisory Committee Meeting.

The TAC meeting in October was attended by the following technical advisors: Jim Gronquist (BPA), Bernie Lesieutre (LBNL), Irena Green (CA ISO). Manu Parashar (EPG) made presentation on the current CA ISO projects including the VSA project.

- The main concepts of the VSA project were supported by the meeting participants
- The only concern was expressed about the convergence of power flow GE-PSLF tool in the vicinity of power flow singularity conditions and its ability to find the PoC point.

4 PROPOSED FRAMEWORK

The overall proposed framework for the year 2005 and beyond that was discussed and formulated with active participation by CERTS consultants Dr. Yuri Makarov and Prof. Ian Dobson and EPG personnel Manu Parashar, Matthew Varghese and Jim Dyer during meetings in Pasadena (August 25-26, 2005) and in Madison (September 9, 2005).

4.1 Selected Study Areas

The selection of the critical parameters influencing the voltage stability margin and stress directions was conducted based on engineering judgment. The stress directions were defined using the sink-source and balanced loading principles. This means that the generators and the loads participating in each stress scenario are identified, as well as their individual participation factors; the participation factors are balanced so that the total of MW/MVAR increments and decrements is equal to zero. This allows avoiding re-dispatching of the remaining generation. Based on the California ISO recommendation, 2 study areas were selected for verifying the prototype VSA algorithms: the Humboldt and San Diego problem areas. The San Diego area was selected as the first to be studied with the RTVSA algorithm.

4.2 Description of Proposed Framework

For each stress direction in each problem area, execute the predictor-corrector procedure to find the Point of Collapse (PoC) in this direction. The selected platform for implementing the procedure includes the PSERC Continuation Power Flow program² and MATLAB programming language. Major modifications have been made to the PSERC program to meet the objectives of the VSA project most efficiently. Details of the procedure are selected as follows:

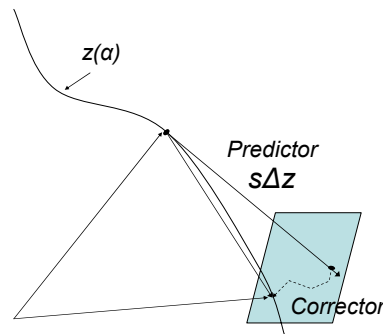

Figure 4 Predictor-Corrector Algorithm

- a. Predictor steps are performed along the parametric trajectory $z(\alpha)$ in the extended state space that includes the power flow state space parameters x plus an additional stress parameter α which defines the current position of power flow points along the stress direction D . The details of Figure 4 are as follows:
 - i. The direction of the step Δz^3 is selected by solving linearized predictor equations and by using one of the following approaches: (1) by fixing an extended state space parameter that experienced the most significant change at the previous predictor step, or (2) by analyzing the angle between the previous increment of state variables and the current direction of the predictor vector Δz (the angle must not exceed certain specified threshold

² Primary authors are S. L. Greene, R. Rajaraman, I. Dobson, F. Alvarado & C. DeMarco

³ The increment vector Δz consists of the increments of nodal voltages and angles Δx and of the stress parameter $\Delta \alpha$.

- value). Measures (1) and (2) are designed to provide one-directional motion along the parametric trajectory.
- ii. The size of the step s is selected based on the maximum allowable changes of per unit nodal voltages and voltage angles.
 - iii. A dichotomy search procedure is implemented to correct (halve) the step size s when the corrector step diverges or the PoC point is being approached. The entire predictor-corrector procedure stops when a specified accuracy (step size) is achieved.
- b. Corrector step follows each predictor steps. The corrector step returns the predicted point to the parametric trajectory $z(\alpha)$ in the extended state space (the deviation occurs because of the linearization used at the preceding predictor step. This is done by fixing the stress parameter at the achieved value, and by solving the corrector equation with the help of the Newton-Raphson method.
 - c. The PoC criterion is based on sign change of the minimum eigenvalue.

5 PROTOTYPE RESULTS

5.1 Description of the San Diego transmission system

The transmission tie-lines forming a boundary around San Diego include: San Onofre - San Luis Rey 1, 2, & 3 230 kV Lines - Path 44 lines- , San Onofre – Talega 1 & 2 230 kV Lines -Path 44 lines, Imperial Valley – Miguel 500 kV line, Imperial Valley – La Rosita 230 kV line, Imperial Valley – El Centro 230 kV line. The San Diego Area boundary substations impacting the area can be defined by San Onofre, San Luis Rey, Talega, Imperial Valley, and Miguel. The diagrams in this section were extracted from R.01-10-024 “Direct Testimony of David Korinek” April 15, 2003.

SDG&E’s ability to import SONGS and other off-system generation is defined by two transmission import boundaries or constraints: the simultaneous import limit (SIL) and SDG&E’s non-simultaneous import limit (NSIL). To help explain these two import conditions, a diagram showing the major import paths & substations is shown in Figure 5. All SDG&E customer load is located within the bubble labeled “Local SDG&E Load Area.” As shown on Figure 5, the NSIL is defined by SDG&E’s ability to import power into its local load area via the five 230 kV lines which comprise the South-of-SONGS (SOS) WECC Path 44.

The SIL is defined by SDG&E’s ability to import power into its system via the Miguel 230 kV bus plus the five 230 kV lines SOS. Based on technical studies, the present NSIL and the SIL limits are 2500 MW and 2850 MW, respectively. The 2850 MW SIL limit applies when all transmission facilities are in operation. Conversely, the NSIL import limit only applies when SDG&E’s 500kV Southwest Power Link (SWPL) is out of operation. These limits define the maximum power imports presently available to serve SDG&E’s load area. If SDG&E’s customer load exceeds these import limits, it must be supplied by local generation within the service area.

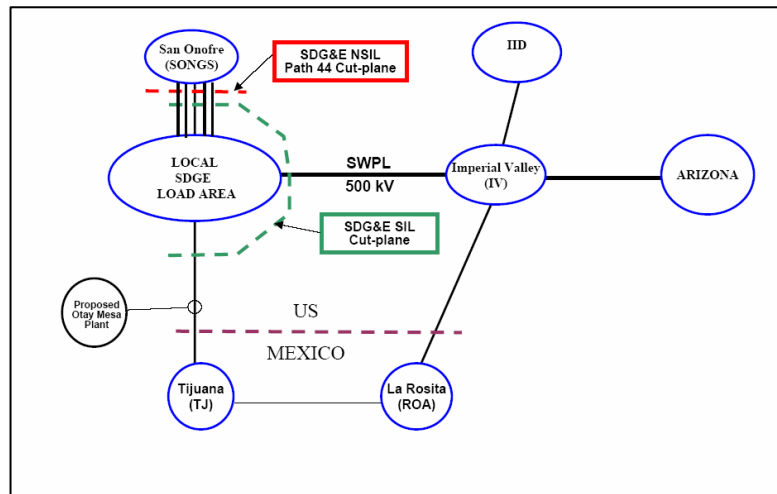

Figure 5 Major Import Paths in the SDGE System

SDG&E's electric transmission network is comprised of 130 substations with 884 miles of 69 kV transmission lines, 265 miles of 138 kV, 349 miles of 230 kV, and 215 miles of 500 kV transmission lines. Figure 6 shows a simplified diagram of the transmission system in San Diego County and southern portion of Orange County, excluding 69kV lines. Local "on system" generating resources are the South Bay Power Plant, connected at 69 kV and 138 kV, and a number of combustion turbine facilities located around the service territory connected at 69kV.

Imported resources are received via the Miguel Substation as the delivery point for power flow on the Southwest Power Link (SWPL), which is SDG&E's 500 kV transmission line that runs from Arizona to San Diego along the US/Mexico Border, and via the SONGS 230kV switchyard – SDG&E's only direct interconnection with the CA ISO controlled grid. Delivery of power from SDG&E's share of the SONGS units flows into the service area as imports at 230kV.

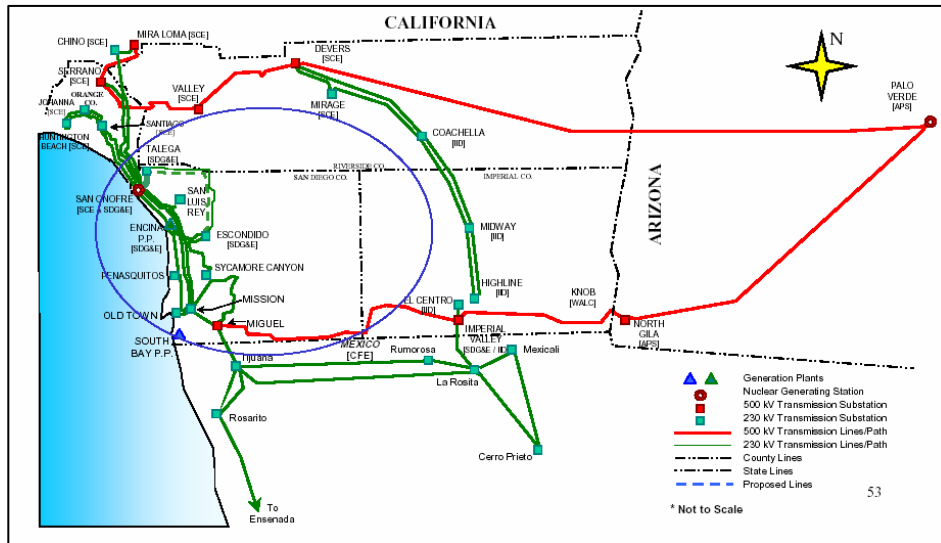

Figure 6 Map showing the two arms of the SWPL corridor in relation to SDGE

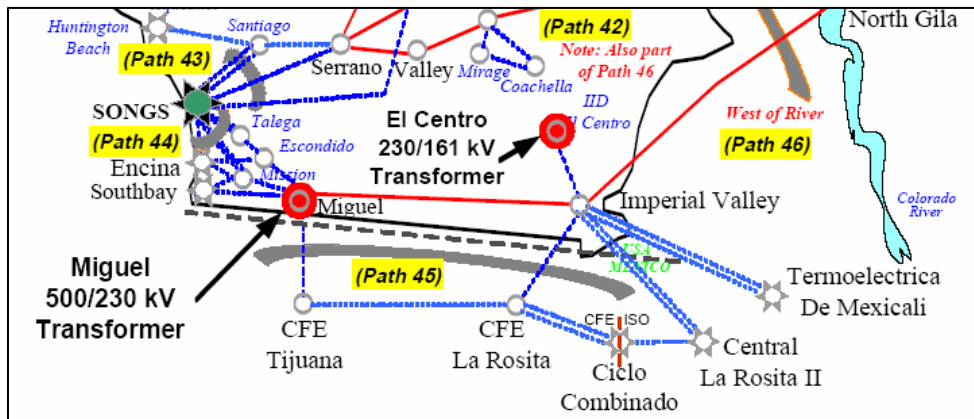

Figure 7 Location of Songs and South Bay in the CA EHV Transmission Network

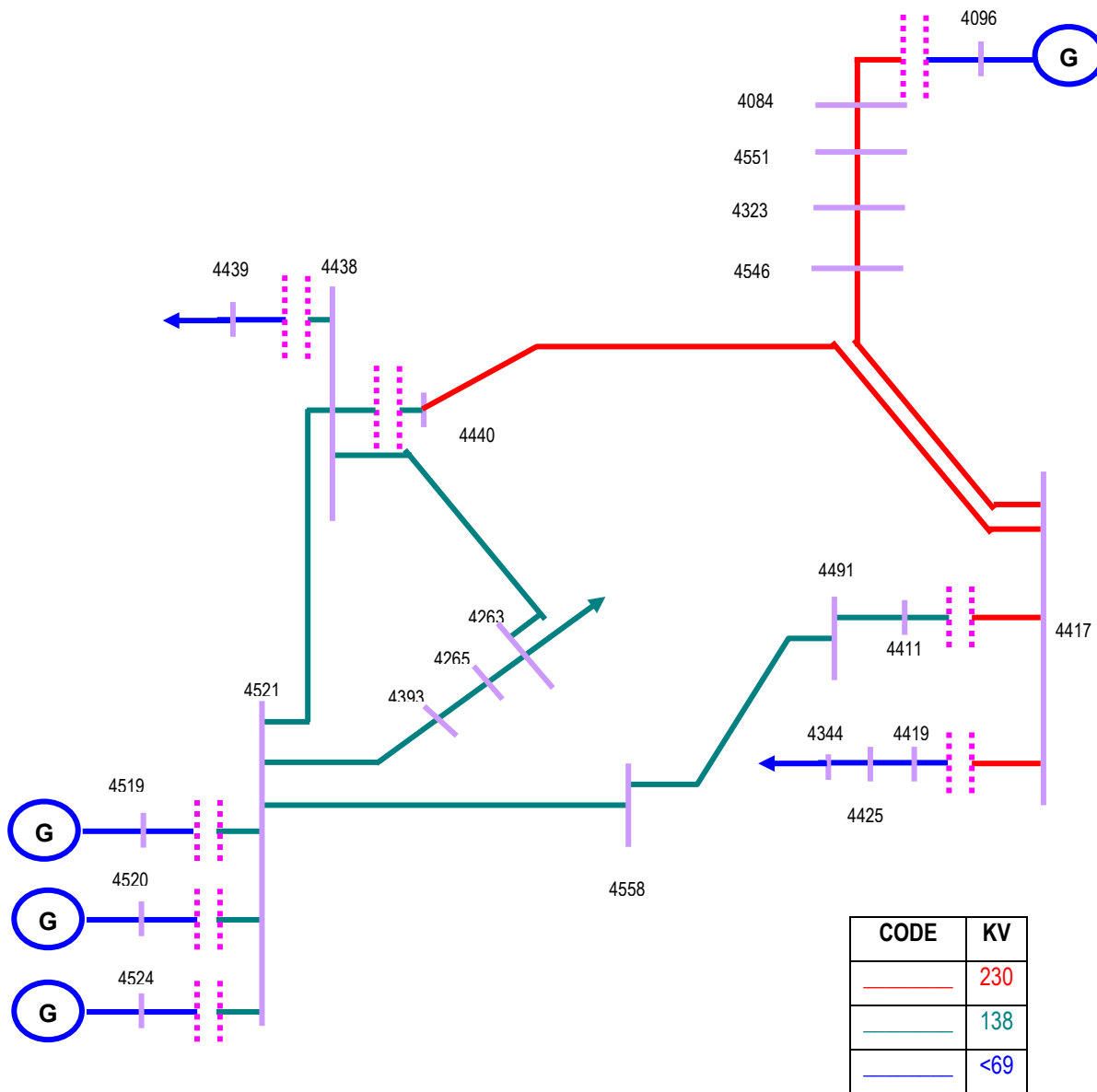

Table 2 Bus Index and Color Code for the SOBAY-MIGUEL-SONGS area

BUS	GENERATOR	BUS	LOAD	BUS	LOAD
4519	SOBAY	4084	SONGS	4393	LCOCHS
4520	SOBAY	4263	CHILLS	4439	MSSION
4524	SOBAY	4323	ESCENDO	4491	PRCTVY
4096	SONGS	4344	GRNITE	4558	TLGCYN
				4417	MIGUEL

Figure 8 One-Lines for the SOBAY-MIGUEL-SONGS area

5.2 Description of Hyperplane Approximation

The hyperplane approximation can be used as a part of the analytical boundary description or separately for the purposes of visualization. See Figure 9 for a geometrical illustration. The first known use of the approximation ideas was apparently related to the *operating nomograms*. See [78] for more details. The operating nomograms are usually represented visually as piecewise linear contours on a plane of two critical parameters. If three critical parameters are involved, the nomogram is represented by a number of contour lines. Each of them corresponds to a certain value of the third parameter. It becomes difficult to visualize nomograms for four or more critical parameters. The natural extension of the linearized stability nomograms for three or more critical parameters is based on the use of *hyperplanes* - the planes that are defined in multidimensional parameter space as approximations of the stability boundary.

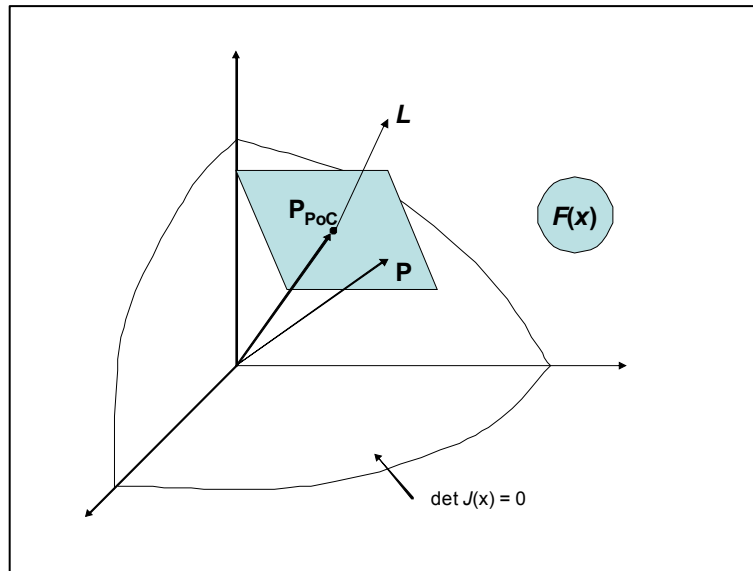

Figure 9 Illustration of Hyperplane Approximation

The RTVSA algorithm produces a tangent hyperplane $p = F(x)$ that can be described by the following formula⁴:

$$L^t \cdot [p - PoC] = 0 \rightarrow p = F(x)$$

Note that:

- It is a tangent plane to the load flow boundary if it is convex at the PoC (Point of Collapse).
- L is the normal to the hyperplane and is identical to the set of Lagrangian multipliers at PoC

The hyperplane is actually a $(n - 1)$ subspace of the n -dimensional space $F(x)$.

⁴ The notation p denotes power injections and x denotes states such as voltage magnitudes and angles.

5.3 On the orientation of 2D hyperplane slices for CHILLS and MISSION

The following input data is used as a simple example to examine the RTVSA prototype. The stress parameters are sinks internal to SDGE. The sources have been constrained to be the set of three generating units at Southbay. This corresponds to a scenario with no import from SONGS or ENCINA or from units West of the River or from Mexico. The SINKS are Loads at Carlton Hills and Mission. The SOURCES are Generator Shifts at South Bay.

Table 3 Patterns of SINK PF (Participation Factors)⁵

Pattern	Color	CHILLS	MSSN	Code	
I	green	0.99	0.01	1	0
II	red	0.20	0.80	1	1
III	blue	0.01	0.99	0	1

Table 4 Generator PF at the 3 Units of South Bay (SB) for all Vectors

SB 4519	SB 4520	SB 4524
0.30	0.35	0.35

5.3.1 Parametric Sensitivities

In Section 5.2, the set of Lagrange multipliers⁶ at PoC are stated to be identical to L , the hyperplane normal. Lagrangian Multipliers at the PoC can also be interpreted as the left eigenvector at the PoC.

Figure 10 shows the comparisons of Lagrangian Multipliers⁷ for the three stressing patterns. For example, Pattern II for CHILLS has a multiplier of 0.8, which means that reducing the load at CHILLS by 1 MW would help to increase the Margin to PoC by 0.8 MW. A bus with a very high Lagrangian Multiplier would signal congestion. Buses with very low Multipliers would be indicative of locations that are a large electrical metric away from the point of collapse. Indicators, such as the statistics of multipliers that are above a certain threshold, can be used for distinguishing the “non-locality” of the collapse phenomenon.

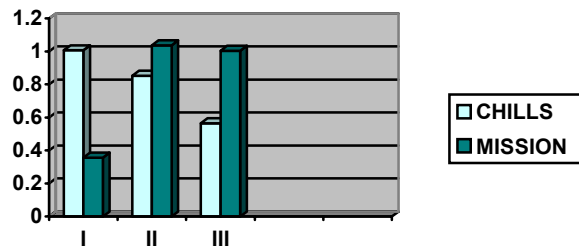

Figure 10 Lagrangian Multipliers for SDGE cases

⁵ The load at Carlton Hills is approximately four times smaller than the load at Mission.

⁶ The coefficients of the hyperplane consist of elements of the *left eigenvector* which can be interpreted as the Lagrangian multipliers corresponding to the parametric sensitivity of the hyperplane. The hyperplanes can be visualized as the constraints in a traditional optimization problem. The intercept on the descriptive variable axis is *inversely proportional* to the Lagrangian multiplier associated with the descriptive variable.

⁷ Local structure such as low voltage networks or radial lines or a persistently congested area may give rise to large spikes in the Lagrange Multipliers. For example, buses at BANING, CABZON, PANSEA, RENWD, SANVEN are at or near generators that are severely VAR limited in the base case. All of these buses are located near DEVERS. The Sensitivities for these buses were filtered out in the screening stage of the RTVSA algorithm.

Figure 11 can be considered a geometric validation of the result. The intercepts on the y axis (Mission) are smaller for patterns II and III because of the larger Lagrangian multipliers for Mission. Likewise, the intercept on the x axis (Carlton Hills) is large for patterns II and III because of the small Lagrange multipliers at Carlton Hills. Stressing Pattern I has the opposite arrangement - a large Lagrangian multiplier for Carlton Hills and a small multiplier for Mission.

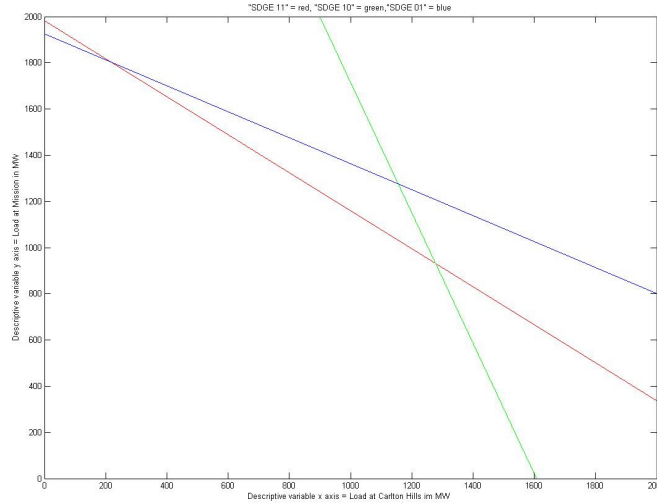

Figure 11 RTVSA Output: Hyperplane slices at Carlton Hills and Mission

The high values of PoC in the CHILLS MSSION case in Figure 11 are because the example was meant to illustrate the effects of electrical limits on the transmission of power from the source buses to a set of distributed sink buses. The effects of thermal limits have been temporarily neglected. The sources are also assumed to have an unlimited supply of reactive power. Both of these relaxations show the electrical capacity of the corridors of power flows from South Bay to CHILLS and MSSION. This capacity is far greater than when thermal and power injection limits are enforced. Such a study is useful in analyzing the effects of large power flows through corridors in the network that may actually occur in the event of an unexpected transfer or large power swings in a pre-collapse scenario.

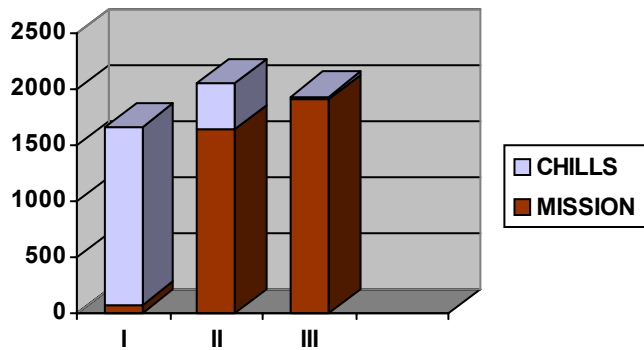

Figure 12 RTVSA Output: PoC in MW for Carlton Hills and Mission

5.3.2 Collapse Participation Factors

The participation is computed from the right eigenvector of the Jacobian evaluated at voltage collapse corresponding to the zero eigenvalue. The right eigenvector provides information on the extent to which variables participate in the voltage collapse. This determines weak areas and whether the collapse is an angle collapse. Specifying to the operator which buses participate most in the voltage collapse is useful, but it should also be noted that the buses with the biggest falls in voltage in the collapse may not be the same as the most effective buses to inject reactive power. These Voltage Collapse Participation Factors can be expressed in terms of KV/(100 MW of the Margin to PoC). In other words, if the Margin to PoC decreases by 100 MW, then the Participation Factors will indicate the extent to which the voltages will recover. Figure 13 shows these for Stressing Pattern I.

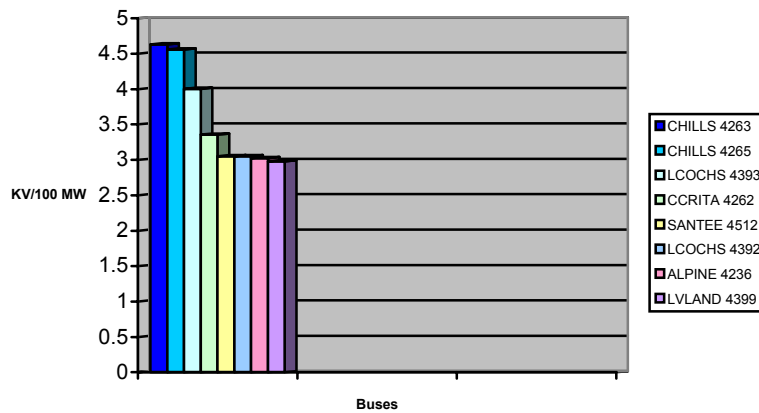

Figure 13 Top Eight Voltage Collapse Participation Factors for Stressing Pattern I

Similar to Voltage Collapse Participation Factors, one can examine the top ranked Angle Collapse Participation Factors. In order to translate between units of KV and units of degrees, the equivalence of 5 degrees and 7 KV has been assumed⁸. See below for Stress Pattern I.

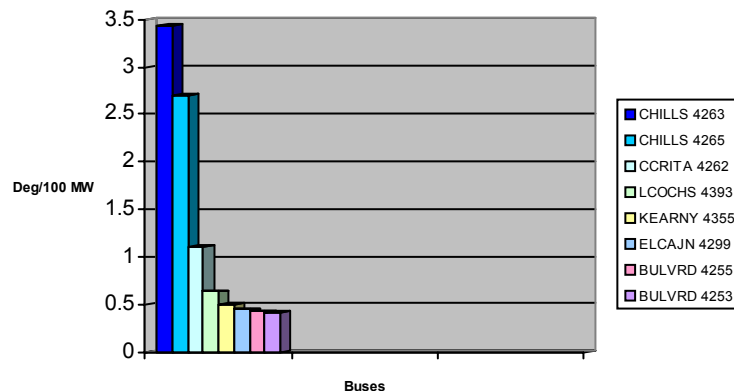

Figure 14 Top Eight Angle Collapse Participation Factors for Stressing Pattern I

⁸ This is based on the original estimates that equates 0.08 radians to 0.05 pu voltage.

In addition, the voltage magnitudes and angles can be plotted versus the stress magnitude to obtain the familiar “nose” curve that shows the sharpness of the collapse as the loading is increased. The Figures below show these for some typical buses.

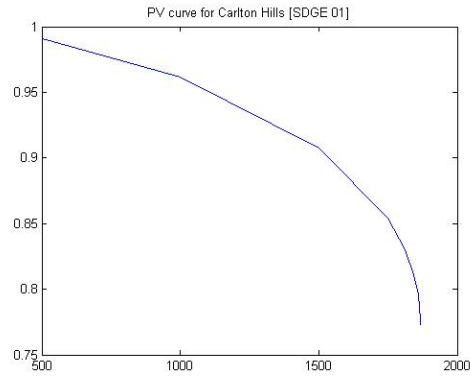

Figure 15 PV curve for Carlton Hills with Stress Pattern III showing collapse

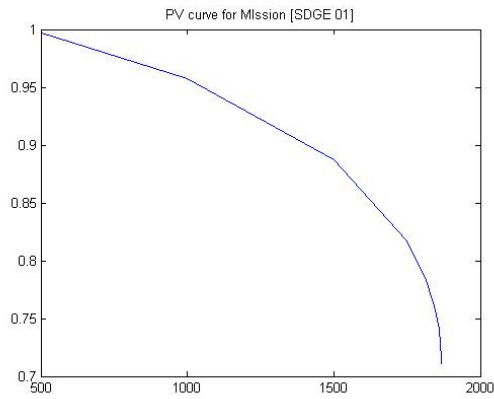

Figure 16 PV curve for Mission with Stress Pattern III showing collapse

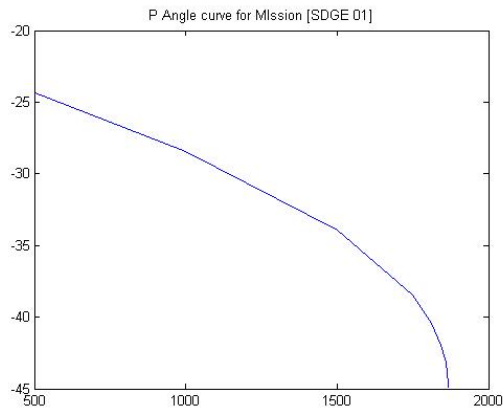

Figure 17 P Angle curve for Mission with Stress Pattern III showing collapse

5.4 On the Effects of Adding a Sink in a Congested Load Pocket

Granite is located a few buses away from Miguel. One of the end points of the South West Power Link (SWPL) is anchored at Miguel. Since Miguel does not have native load, the stressing of Granite as a sink can be viewed as an indirect perturbation of the power flows in the Miguel to Imperial Valley arm of the SWPL transfer corridor. The SINKS are Loads at Carlton Hills, Mission and Granite. The SOURCES are Generator Shifts at 3 units at South Bay. These units have equal PF (Participation Factors) for all Patterns.

Table 5 Patterns of SINK PF (Participation Factors)

CHILLS	MSSION	GRNITE	Color	Code		
0.33	0.34	0.33	green	1	1	1
0.02	0.49	0.49	cyan	0	1	1
0.49	0.02	0.49	magenta	1	0	1
0.49	0.49	0.02	red	1	1	0

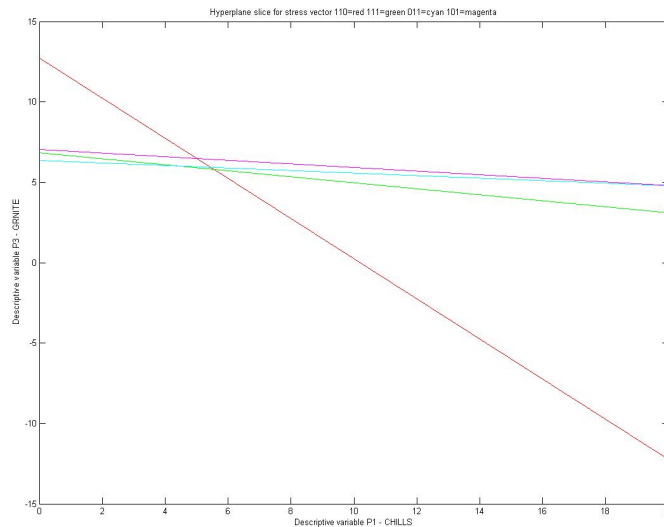

Figure 18 RTVSA Output: Hyperplane slices for Granite and Mission

The load at Granite Hills is located in a relatively congested area near Loveland and Los Coches. When the load at Granite is picked as one of the descriptive variables, the stressing patterns corresponding to {111} {011} {101} are very different compared to the pattern {110}. This is the only pattern to have a very small stress at Granite. The “flatness” of the {111} {011} {101} patterns can be attributed to the “easily congested paths” connected to the *load* at Granite. The smaller intercept on the Granite axis for the {111} {011} {101} patterns correspond to larger Lagrangian multipliers which is an expression of greater systemic congestion.

5.5 Description of the Humboldt transmission system

The Humboldt area is shown in the Figures below. The transmission tie lines into the area include Humboldt-Bridgeville 115 kV line 1, Humboldt-Trinity 115 kV line 1, Willits-Garberville 60 line kV1, and Trinity-Maple Creek 60 kV. The substations that delineate the Humboldt Area are Low Gap 115 kV and Humboldt 115 kV. The most critical contingencies for the Humboldt area involve (1) the loss of the Bridgeville-Cottonwood 115 kV line along with one Humboldt Bay Power Plant and (2) the loss of the Humboldt-Trinity 115 kV line along with one Humboldt Bay Power Plant. These contingencies are limited by the reactive power margin. They establish the target of 162 MW as the minimum capacity necessary for the Humboldt area with 126 MW of the Local Capacity requirement at 36 MW of the municipal and Qualifying Facility (QF) generation.

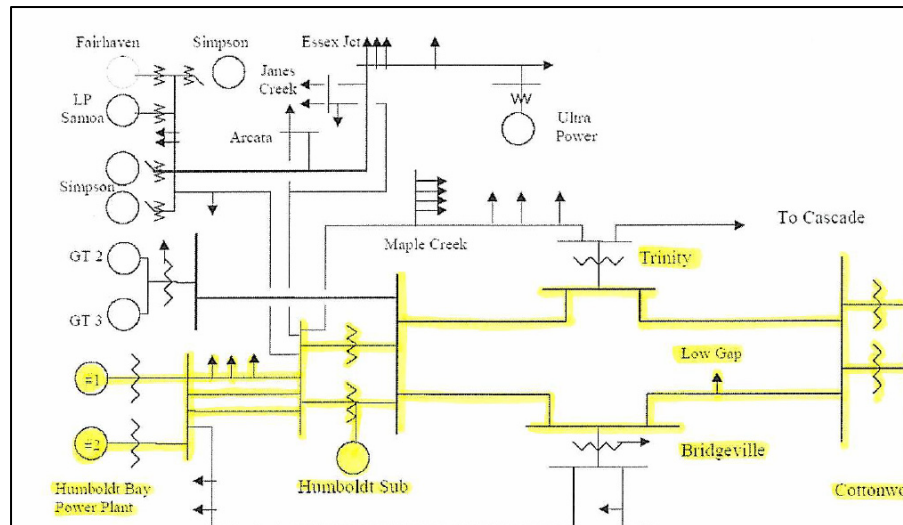

Figure 19 Humboldt Area

The Humboldt area covers most of Humboldt County. The grid is comprised of 60 kV and 115 kV transmission lines. Internal generation in the Humboldt area consists of two 53 MW thermal generating units, two 15 MW mobile gas turbines (GTs), one 25 MW biomass self-generator and 36 MW of QF generation.

Additionally, there is one off-line generator in the area having a capacity of 10 MW. The Humboldt Area includes the city of Eureka. This area has a winter peak load of approximately 190 MW. Pacific Gas & Electric (PG&E) owns the transmission and distribution systems in the Humboldt area. The major transmission lines serving this area are two 115 kV lines from Cottonwood and one 60 kV line from Trinity in the east and one 60 kV line from Garberville in the south.

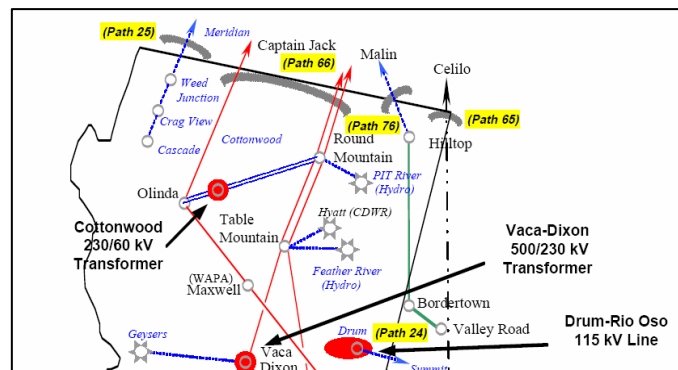

Figure 20 Location of Cottonwood in the CA EHV Transmission Network

The import capability of the existing transmission system supplying the Humboldt Area is a function of the load in the Humboldt Area and the amount of internal generation on-line. The transmission system alone is capable of serving approximately 70 MW of load. Internal generation in the Humboldt Area consists of two 53 MW thermal generators, two 15MW mobile gas turbines (GTs), one 25 MW biomass generator, as well as 46 MW of Qualifying Facility (QF) generation. However there are currently other four off line generators in the area with a total of about 72 MW. All numbers are nameplate capacity.

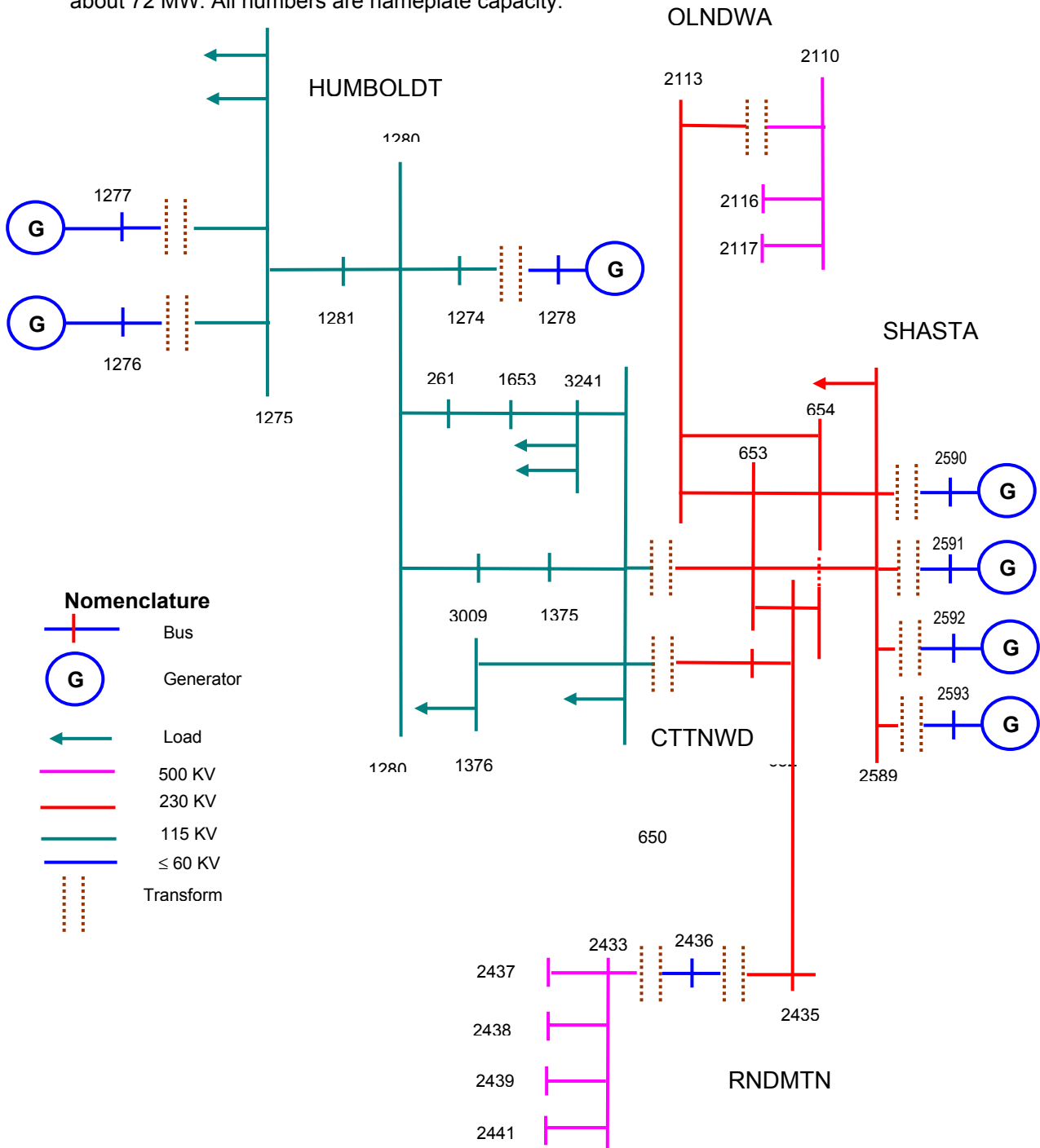

Figure 21 One Lines for the HUMBOLDT CTTNWD SHASTA area

5.6 Stress Patterns and RTVSA Results for Humboldt

The stress patterns permuted the set of generation in Shasta and the Humboldt power plants. The sinks were kept unchanged at Cottonwood and Jessup. Shasta provides almost all of the generation in Pattern I. Humboldt provides one and a half times more generation than Shasta in Pattern II. The results in Figure 22 and Figure 23 are for these generator descriptive variables.

Table 6 List of Humboldt Stressing Patterns

Pattern	Color	Source Vector			Sink Vector		
		Bus Number	Bus Name	Participation Factors	Bus Number	Bus Name	Participation Factors
I	Red	1276	HUMBOLDT	0.05	650 1376	CTTNWD JESSUP	0.6 0.4
		1277	HUMBOLDT	0.05			
		2590	SHASTA	0.22			
		2591	SHASTA	0.23			
		2592	SHASTA	0.22			
		2593	SHASTA	0.23			
II	Blue	1276	HUMBOLDT	0.30	650 1376	CTTNWD JESSUP	0.6 0.4
		1277	HUMBOLDT	0.30			
		2590	SHASTA	0.10			
		2591	SHASTA	0.10			
		2592	SHASTA	0.10			
		2593	SHASTA	0.10			

Table 7 Index for Humboldt Bus Numbers

BUS	NAME	BUS	NAME	BUS	NAME
650	CTTNWD	261	BRDGLV	1653	LOWGAP
652	CTTNWD	1375	JESSTAP	3009	TRINITY
653	CTTNWD	1376	JESSUP	3241	WILDWD
654	CTTNWD				
1274	HUMBOLDT	2589	SHASTA	2592	SHASTA
1275	HUMBOLDT	2590	SHASTA	2593	SHASTA
1276	HUMBOLDT	2591	SHASTA	1280	HUMBOLDT
1277	HUMBOLDT	1278	HUMBOLDT	1281	HUMBOLDT

The results in Figure 22 and Figure 23 emphasize the role of the generators at Shasta and Humboldt as descriptive variables. Negative Lagrangian Multipliers endow both hyperplane slices with positive slopes in the space of generator descriptive variable space.

A generator injection can be regarded as parameterizing a redispatch or transfer. Increasing a generator must be balanced by decreasing the distributed slack bus so what one is really looking at is the effect on voltage collapse of various transfers. A general transfer can either increase a voltage collapse margin or decrease it and this is what gives different signs of the hyperplane equation. On the other hand, loads are easier to model as descriptive variables because it is usually the case that increasing loads decrease voltage collapse margins. In particular, a negative multiplier means that increasing the transfer increases the margin, at least locally in the region of validity of the hyperplane. It is easy to construct such cases. Simply take a transfer that makes voltage collapse worse and reverse it so that source becomes sink and sink becomes source. This is the same as considering minus the transfer. For "nomogram-like" results one has to ensure that increasing all the descriptive variables make voltage collapse worse. One can probably do this by flipping the signs of some of the transfers.

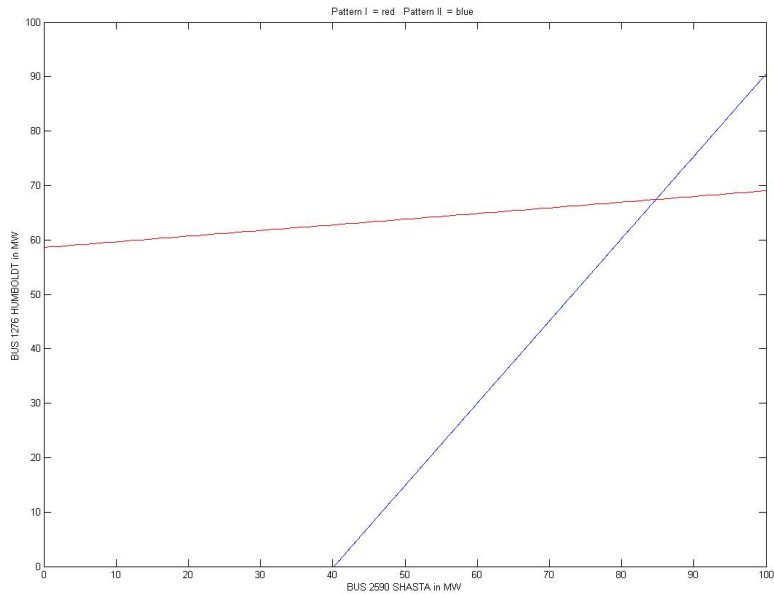

Figure 22 RTVSA Output: Hyperplane slices at Humboldt 1276 and Shasta 2590

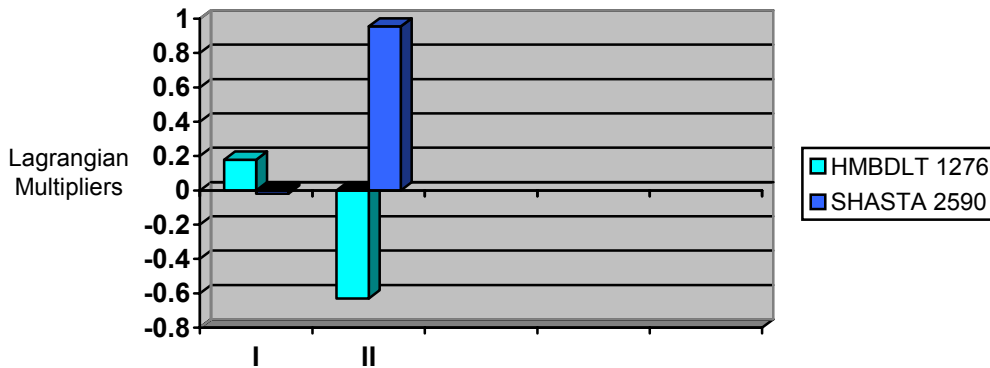

Figure 23 RTVSA Output: Lagrangian Multipliers for Humboldt

5.7 Discussions on Exploring Patterns of Loading

Considering all the theoretically possible patterns of loading, even if computationally feasible, is probably not desirable because it would imply reacting to voltage collapse situations that would not arise in practice. We are generally only interested in the voltage collapses that would result from the practically feasible patterns of loading that the power system could actually experience in the next few hours. Then a central question is how to specify the practically feasible patterns of loading. One can compute worst-case patterns of loadings to obtain worst-case margins. However, there can be several such locally worst-case patterns of loadings and some of these may correspond to unrealistic system loadings. The multiple worst-case loadings can correspond to voltage collapses concentrated in different areas. Some options are given below.

- The patterns of loading can be predicted in real time. The customer load can be forecast and there should also be information about the likely bulk power transfers. However, the uncertainties and time frames of the predictions need to be managed.
- The operators may wish to specify patterns of loading that are meaningful or relevant to them. One can use past experience to select typical or worst-case patterns of loadings. Certain classes of patterns of loading can be associated with voltage collapses concentrated in different areas.
- Patterns of loading that give the best hyperplane approximations to the voltage collapse boundary for practically feasible loadings could be sought.
- Note that patterns of loading need to be fully defined in terms of injections at each generator and load bus. For example, in specifying a north-south bulk power transfer, the participation of each of the ramping up and ramping down generators needs to be specified. The choices of these participations can be determined from real-time data, from typical realistic cases, or from operator input.

6 CONCLUSIONS

The efficacy of using hyperplanes to approximate the boundary described by the Point of Collapse phenomenon is prone to a few caveats. The hyperplane approximation is only as good as the set of stressing vectors that are provided as input to the parameter continuation power flow. A set of “basis” vectors must be formulated that is “rich enough” to fully capture all possible stresses that the system might experience. Additionally, the Point of Collapse is usually indexed by a pre-determined set of contingencies. Each of these contingencies will spawn a parallel offline data structure to store the coefficients of the set of hyperplanes to be used in an on-line fashion when an outage is predicted.

Some of the intensive storage requirements for hyperplane coefficients along with the set of basis stress vectors may be relaxed if the boundary structure is observed to be cylindrical. The notion of such a “cylindrical” structure⁹ is manifested in the “flatness” of certain sets of stressing vectors. For example, the effect of adding a sink show that patterns {111} {101} {011} are redundant in the descriptive variable space that includes Granite Hills. The “flatness” of these slices is because of the very small Lagrangian multipliers associated with Mission and Carlton Hills for the {111} {101} {011} stress patterns. The “flatness” of these hyperplane slices implies that it is safe to further load the system in the Carlton Hills and Mission direction. The overlaying of the {110} stress vector does somewhat reduce the safe area of operation, which is precisely the same effect that an additional constraint would have on a standard nomogram application.

Determining the set of Lagrangian multipliers or parametric sensitivities at the exact PoC has the advantage in predicting precisely the controllable elements in the space of power injections that are responsible for the collapse. The next phase of this project will improve on the parameter continuation power flow by determining the exact PoC with a direct method. More meaningful descriptive variables such as cut-set flows should be used in determining the boundary of collapse. The on-line availability of distribution factors¹⁰ that map injections to cut-sets should help to improve the hyperplane identifier.

⁹ From *Descriptive variables, operational hypersurfaces, and nomograms* by Ian Dobson Nov 25, 2005 – “Cylindrical view of the induced hypersurface” - To visualize the relation of the nomogram hypersurface S_n , the induced hypersurface S_i and the security hypersurface S we change coordinates so that S_i is a cylinder. Suppose there are k descriptive variables and n parameters where $k < n$. The coordinates of parameter space are changed so that the first k of the n coordinates are the descriptive variables. For example, if $n=3$ and there are $k=2$ descriptive parameters and one other parameter and S_n is the arc of a circle, then S_i is an arc of the surface of a cylinder. The issue of approximating the security hypersurface S by S_i is how well S can be approximated by an S_i of cylindrical form inside S .

¹⁰ An example is the EPRI Interchange Distribution Calculator

Note that while the worst case loading margin computation may well be useful, the worst case is sometimes an unrealistic pattern of loading that would not happen in practice. It is better to use the hyperplane methods to be restricted to practically feasible loadings. The experience seems to be that the closest bifurcation direction search should be restricted to feasible cones. The metric for the closest bifurcation should also be scrutinized according to the intended use of the closest bifurcation information: The Euclidean norm gives a measure of parameter space robustness but it does not give the increase in load or generator powers given by an L1 norm.

REFERENCES

- [1] P. Kundur, Power System Stability and Control, New York: McGraw-Hill, 1994.
- [2] S. Lindahl, "Case studies of recent blackouts", CRIS International Workshop on Power System Blackouts ~ Causes, Analyses, and Countermeasures, Lund, Sweden, May 3, 2004.
- [3] Final Report on the August 14, 2003 Blackout in the United States and Canada: Causes and Recommendations, U.S. – Canada Power System Outage Task Force, April 5, 2004. Available online at <http://www.nerc.com/~filez/blackout.html>.
- [4] G. Doorman, G. Kjølle, K. Uhlen, E. S. Huse, and N. Flatabø, "Vulnerability of the Nordic Power System", Report to the Nordic Council of Ministers, SINTEF Energy Research, May 2004. Available online at <http://sparky.harvard.edu/hepg/Papers/Doorman.vul.nordic.system.0504.pdf>
- [5] A. Kurita and T. Sakurai, "The Power System Failure on July 23, 1987 in Tokyo", in Proceedings of the 27th Conference on Decision and Control, December 1988.
- [6] G.C. Bullock, "Cascading Voltage Collapse in West Tennessee, August 22, 1987", Georgia Institute of Technology 44th Annual Protective Relaying Conference, May 2--4 1990.
- [7] "The Electric Power Outages In The Western United States, July 2-3, 1996", DOE Report to the President, August 2, 1996. Available online at ftp://www.nerc.com/pub/sys/all_updl/docs/pubs/doerept.pdf.
- [8] "Western Systems Coordinating Council Disturbance Report for the Power System Outage that Occurred on the Western Interconnection on August 10, 1996", October 18, 1996. Available online at ftp://www.nerc.com/pub/sys/all_updl/docs/pubs/AUG10FIN.pdf.
- [9] "California ISO System Disturbance Report: December 8, 1998 - San Francisco Area". Available online at <http://www.CAISO.com/docs/1999/03/31/1999033116341717931.pdf>
- [10] N. Dizdarevic, M. Majstrovic, S. Cudjic Coko, N. Mandic, and J. Bonovic, "Causes, Analyses and Countermeasures with Respect to Blackout in Croatia on January 12, 2003", CRIS International Workshop on Power System Blackouts ~ Causes, Analyses, and Countermeasures, Lund, Sweden, May 3, 2004.
- [11] "Technical Analysis of the August 14, 2003, Blackout: What Happened, Why, and What Did We Learn?", Report to the NERC Board of Trustees by the NERC Steering Group, July 13, 2004. Available online at ftp://www.nerc.com/pub/sys/all_updl/docs/blackout/NERC_Final_Blackout_Report_07_13_04.pdf
- [12] "Power failure in Eastern Denmark and Southern Sweden on 23 September 2003", Final report on the course of events, Ekraft System, November 4, 2003. Available online at <http://www.elkraft-system.dk>
- [13] "The Black-Out In Southern Sweden and Eastern Denmark", 23 September, 2003, Preliminary Report, PM 2003-10-02, Svenska Kraftnät. Available at http://www.svk.se/upload/3195/Disturbance_Sweden_DenmarkSept23.pdf
- [14] "Interim Report of The Investigation Committee on the 28 September 2003 Blackout in Italy", Press Release, Union for the Coordination of Transmission of Electricity UCTE, Brussels, Belgium, October 3, 2003. Available online at <http://www.energie-schweiz.ch/imperia/md/content/medienmitteilungen/mmm06-122003/82.pdf>
- [15] "Black-Out: The Events Of 28 September 2003", Press Release, Gestore Rete Transmisioni Nazionale, Italy, October 1, 2003. Available online at <http://www.grtn.it/eng/documentinewsstache/blackout28set03.pdf>

- [16] C. Vournas, "Technical Summary on the Athens and Southern Greece Blackout of July 12, 2004". Available online at http://www.pserc.org/Greece_Outage_Summary.pdf.
- [17] Отчет по расследованию аварии в ЕЭС России, произошедшей 25.05.2005. Председатель комиссии по расследованию аварии В.К.Паули, 18 июня 2005г. [Report on failure inquiry in UES of Russia that took place at May 25,2005 – in Russian]. Available online at: http://www.mosenergo.ru/download/r410_account.zip.
- [18] "Voltage Stability of Power Systems: Concepts, Analytical Tools, and Industry Experience", IEEE Special Publication 90TH0358-2-PWR, 1990.
- [19] "Modeling of Voltage Collapse Including Dynamic Phenomena", CIGRE Task Force 38-02-10, 1993.
- [20] P. W. Sauer, K. Tomsovic, J. Dagle, S. Widergren, T. Nguyen, and L. Schienbein, "Integrated Security Analysis", Final Report, CERTS, July 2004. Available online at http://certs.lbl.gov/CERTS_P_RealTime.html.
- [21] "Memorandum on the Development and the Reasons of the East Coast US Blackout on August 14, 2003", Department of Relay Protection and Automatics, SO-CDA, September 10, 2003 – in Russian.
- [22] S. Vakhterov, "It Was Possible to Avoid the Blackout", Power Market, No. 1, 2004. – In Russian.
- [23] Y. V. Makarov, V. I. Reshetov, V. A. Stroeve, and N. I. Voropai, "Blackout Prevention in the United States, Europe and Russia", Proceedings of the IEEE - Special Issue on Power Technology & Policy "Forty years after the 1965 Blackout", Vol. 93, No. 11, November 2005, pp. 1942-1955 (Invited paper).
- [24] "Voltage Stability Criteria, Undervoltage Load Shedding Strategy, and Reactive Power Reserve Monitoring Methodology", Final Report, Reactive Power Reserve Work Group, Western Electricity Coordinating Council, May 1998. Available online at <http://www.wecc.biz/modules.php?op=modload&name=Downloads&file=index&req=getit&lid=1038>.
- [25] T. Van Cutsem and R. Mailhot, "Validation of a Fast Voltage Stability Analysis Method on the Hydro-Quebec System", IEEE Transactions on Power Systems, Vol. 12, No. 1, pp. 282-292, February 1997.
- [26] B. Gao, G. K. Morrison, and P. Kundur, "Voltage Stability Evaluation Using Modal Analysis", IEEE Trans. on Power Systems, Vol. 7, No. 4, November 1992, pp. 1529-1542.
- [27] "Reliability Criteria", Western Electricity Coordinating Council, April 2005. Available online at <http://www.wecc.biz/modules.php?op=modload&name=Downloads&file=index&req=getit&lid=1029>
- [28] C. W. Taylor, Power System Voltage Stability. New York: McGraw-Hill, 1994.
- [29] T.J.E Miller, Editor, Reactive Power Control in Electric Systems. New York: John Wiley & Sons, 1982
- [30] H. K Clark, "More attention to reactive [power] and voltage will present opportunities to improve grid reliability", DOE Blackout forum, December 22, 2003. Available online at http://www.electricity.doe.gov/govforums/view_thread2.cfm?post_id=186.
- [31] T. Van Cutsem, I. Dobson (Editor), C. DeMarco, D. Hill, I. Hiskens, T. Overbye, M. Venkatasubramanian, C. Vournas, Basic Theoretical Concepts, Chapter 2, IEEE Voltage Stability Work Group Report, April 1998. Available online at <http://eceserv0.ece.wisc.edu/~dobson/WG/>.
- [32] B.M. Weedy and B.R. Cox, "Voltage stability of radial power links", Proc. IEEE, Vol.115, pp. 528-536, April 1968.

- [33] P. M. Anderson and A. A. Fouad. Power System Control and Stability, IEEE Press, New York 1994.
- [34] A. M. Lyapunov, The General Problem of the Stability of Motion, London, Washington DC, Taylor & Francis, 1992.
- [35] R. Seydel, From Equilibrium to Chaos: Practical Bifurcation and Stability Analysis, Springer-Verlag, New York, 1994.
- [36] S. Strogatz, Nonlinear Dynamics and Chaos: with Applications in Physics, Biology, Chemistry, and Engineering, Addison-Wesley, Reading MA, 1994.
- [37] Thompson, J.M.T., Stewart, H.B., Nonlinear Dynamics and Chaos: Geometrical Methods for Engineers and Scientists, John Wiley, New York, 1986.
- [38] E.H. Abed, P.P. Varaiya, "Nonlinear Oscillations in Power Systems", International Journal of Electric Energy and Power Systems, vol. 6, no. 1, January 1984, pp. 37-43.
- [39] C.-W. Tan, M. Varghese, P. Varaiya, F.F. Wu, "Bifurcation, Chaos, and Voltage Collapse in Power Systems", Proceedings of the IEEE, Special issue on nonlinear phenomena in power systems, November 1995, vol. 83, no. 11, pp. 1484-1539.
- [40] V. Ajjarapu and B. Lee, "Bibliography on Voltage stability", Available online at <http://www.ee.iastate.edu/~venkatar/Biblio/biblio.html#Group5>.
- [41] V. A. Venikov, V. A. Stroeve, V. I. Idelchick, and V. I. Tarasov, "Estimation of electric power system steady-state stability in load flow calculation", IEEE Trans. on Power Apparatus and Systems, Vol. PAS-94, pp.1034 - 1041, May/June 1975.
- [42] R. C. Hardiman, M. Kumbale, and Y. V. Makarov, "An Advanced Tool for Analyzing Multiple Cascading Failures", Proceedings of the 8th International Conference on Probabilistic Methods Applied to Power Systems, Iowa State University, Ames, Iowa, September 12-16, 2004.
- [43] I. Dobson, "The Irrelevance of Load Dynamics for the Loading Margin to Voltage Collapse and its Sensitivities", in L. H. Fink, Editor, Bulk power system voltage phenomena III, voltage stability, security & control, Proceedings of the ECC/NSF workshop, Davos, Switzerland, August 1994.
- [44] C.A. Canizares, Conditions for saddle-node bifurcations in AC/DC power systems, Electrical Energy & Power Systems, Vol. 17, No. 1, pp. 61-68, 1995.
- [45] Y. V. Makarov, D. H. Popovic, and D.J. Hill, "Stabilization of Transient Processes in Power Systems by an Eigenvalue Shift Approach", IEEE Transactions on Power Systems, Vol. 13, Issue 2, May 1998, pp. 382 – 388.
- [46] Yu. E. Gurevich, L.E. Libova, and A.A. Okin, "Design of Stability and Emergency Control Automatic Devices in Power Systems", Energoatomizdat, Moscow, 1990 – in Russian.
- [47] R. R. Austria, X. Y. Chao, N. P. Reppen, and D. E. Welsh, "Integrated Approach to Transfer Limit Calculations", IEEE Computer Applications in Power, January 1995, pp. 48-52.
- [48] B. Gao, G.K. Morison and P. Kundur, "Towards the Development of a Systematic Approach for Voltage Stability Assessment of Large-Scale Power Systems", IEEE Transactions on Power Systems, Vol. PWRS-11, No. 3, August 1996, pp. 1314-1324.
- [49] V.A. Matveev, "A Method of Numeric Solution of Sets of Nonlinear Equations", Zhurnal Vychislitelnoi Matematiki I Matematicheskoi Fiziki, Vol. 4, No. 6, pp. 983-994, 1964 - in Russian.
- [50] V.I. Tarasov, "Implementation of a Permanent Loading Procedure to Definition of Load Flows on a Limit of Aperiodic Steady-State Stability", Voprosy primeneniya matematicheskikh metodov pri upravlenii regimami i razvitiem elektricheskikh sistem, Irkutsk, pp. 50-56, 1975 – in Russian.

- [51] A.M. Kontorovich, Y.V. Makarov and A. A. Tarakanov, "Improvements of a Permanent Loading Technique to Compute Load Flows on Stability Margin", Trudy LPI, No. 380, pp. 37-41, 1982 - in Russian.
- [52] A. M. Kontorovich and Y. V. Makarov, "A permanent loading technique for fast analysis of power system stability limit load flows", USSR National Scientific and Technical Conference "Problems of Stability and Reliability of the USSR Power System", Dushanbe, 1989 – In Russian.
- [53] P. Kessel and H. Glavitsch, "Estimating the voltage stability of a power system", IEEE Transactions on Power Delivery, Vol.PWRD-1, No. 3, July 1986, pp. 346-354.
- [54] G. B. Price, "A generalized circle diagram approach for global analysis of transmission system performance", IEEE Trans. Power Apparatus and Systems, Vol. PAS-103, No. 10, pp. 2881–2890, October 1984, pp. 2881-2890.
- [55] V. Ajjarapu and C. Christy, "The Continuation Power Flow : A Tool to Study Steady State Voltage Stability," IEEE Transactions on Power Systems, Vol. 7, No. 1, February 1992, pp. 416-423.
- [56] T. Van Cutsem, C. Vournas, "Voltage Stability of Electric Power Systems", Kluwer Academic Publishers (Power Electronics and Power Systems Series), Boston, 1998
- [57] A. Bihain, G. Burt, F. Casamatta, T. Koronides, R. Lopez, S. Massucco, D. Ruiz-Vega, and C. Vournas, "Advanced Perspectives and Implementation of Dynamic Security Assessment in the Open Market Environment", CIGRE 2002, France, August 2002.
- [58] J. Jarjis and F.D. Galiana, "Quantitative Analysis of Steady State Stability in Power Networks", IEEE Trans. On Power Apparatus and Systems, Vol. PAS-100, No. 1, January 1981, pp. 318-326.
- [59] A.M. Kontorovich, A.V. Kryukov, Y.V. Makarov, et al, Methods of stability indices computations for complicated power systems, Publishing House of the Irkutsk University, Irkutsk, 1988 (in Russian).
- [60] C.A. Cañizares and F.L. Alvarado, "Computational Experience with the Point of Collapse Method on Very Large AC/DC Systems", Proceedings: Bulk Power System Voltage Phenomena - Voltage Stability And Security, ECC/NSF Workshop, Deep Creek Lake, MD, August 1991; published by ECC Inc., Fairfax, Virginia.
- [61] T. Van Cutsem, "A method to compute reactive power margins with respect to voltage collapse", IEEE Trans. on Power Systems} Vol. 6, No. 1, February 1991, pp. 145-156.
- [62] C. A. Cañizares, , F. L. Alvarado, C. L. DeMarco, I. Dobson, W. F. Long, "Point of Collapse Methods Applied to AC/DC Power Systems", IEEE Transactions on Power Systems, Vol. 7, Issue 2, May 1992, pp. 673 – 683.
- [63] I. Dobson, "Observations on the Geometry of Saddle Node Bifurcation and Voltage Collapse in Electrical Power Systems", IEEE Transactions on Circuits and Systems I: Fundamental Theory and Applications, Vol. 39, Issue 3, March 1992, pp. 240 – 243.
- [64] P. W. Sauer and B. C. Lesieutre, "Power System Load Modeling", J. H. Chow, P. V. Kokotovic and R. J. Thomas, (Editors), Systems and Control Theory for Power Systems, Springer-Verlag 1995, pp. 283-313.
- [65] P. A. Löf, T. Smed, G. Andersson, and D. J. Hill, "Fast Calculation of a Voltage Stability Index," IEEE Trans. Power Systems, vol. 7, no. 1, pp. 54–64, February 1992.
- [66] Y. Tamura, H. Mori, and S. Iwamoto, "Relationship Between Voltage Instability and Multiple Load Flow Solutions in Electric Power Systems," IEEE Trans. on Power Apparatus and Systems, Vol.PAS-102, pp.1115 --1123, May 1983.

- [67] C.J. Parker, I.F. Morrison, and D. Sutanto, "Application of an Optimization Method for Determining the Reactive Margin From Voltage Collapse in Reactive Power Planning," IEEE Trans. Power Systems, Vol. 11, No. 3, August 1996, pp. 1473–1481.
- [68] G.D. Irisarri, X. Wang, J. Tong, and S. Mokhtari, "Maximum Loadability of Power Systems Using Interior Point Non-linear Optimization Method," IEEE Trans. Power Systems, Vol. 12, No. 1, February 1997, pp. 162-172.
- [69] "Operations Review of June 14, 2000 PG&E Bay Area System Events Using AEMPFAS^T® Software", Consultant Report P500-03-085F, Prepared by CERTS for the California Energy Commission, October 2003.
- [70] I. Dobson and L. Lu, "Computing an Optimal Direction in Control Space to Avoid Saddle Node Bifurcation and Voltage Collapse in Electric Power Systems", IEEE Trans. on Automatic Control, Vol. 37, No. 10, October 1992, pp. 1616-1620.
- [71] I. Dobson, L. Lu and Y. Hu, "A Direct Method for Computing a Closest Saddle Node Bifurcation in the Load Power Parameter Space of an Electric Power System", IEEE International Symposium on Circuits and Systems, Singapore, June 1991, pp. 3019-3022.
- [72] I. Dobson and L. Lu, 'New Methods for Computing a Closest Saddle Node Bifurcations and Worst Case Load Power Margin for Voltage Collapse', IEEE Trans. on Power Systems, Vol. 8, No. 3, August 1993, pp. 905-913.
- [73] F. Alvarado, I. Dobson and Y. Hu, "Computation of Closest Bifurcations in Power Systems", IEEE Trans. on Power Systems, Vol. 9, No. 2, May 1994, pp. 918-928.
- [74] Y.V. Makarov, Q. Wu, D.J. Hill, D.H. Popovic and Z.Y. Dong, "Coordinated Steady-State Voltage Stability Assessment and Control", Proc. International Conference on Advances in Power System Control, Operation and Management APSCOM'97, Wanchai, Hong Kong, November 11-14, 1997.
- [75] J. Kanetkar and S. Ranade, "Compact Representation of Power System Security - A Review," Proceedings of the North American Power Symposium, Reno, Nevada, 1992, pp. 312-321.
- [76] F. D. Galiana, "Power Flow Feasibility and the Voltage Collapse Problem", Proceedings of 23rd CDC, Las Vegas, NV, December 1984, pp. 485-487.
- [77] P. Kessel and H. Glavitsch, "Estimating the Voltage Stability Regions of a Power System," IEEE Transactions Power Delivery, Vol. PWRD-1, July 1986, pp. 346-354.
- [78] J. D. McCalley, S. Wang, R. T. Treinen, and A. D. Papalexopoulos, "Security Boundary Visualization for Systems Operation", IEEE Transactions on Power Systems, Vol. 12, No. 2, May 1997, pp. 940-947.
- [79] G. Zhou and J. D. McCalley, "Composite Security Boundary Visualization", IEEE Transactions on Power Systems, Vol. 14, No. 2, May 1999, pp. 725-731.
- [80] J. Su, Y. Yu, H. Jia, P. Li, N. He, Z. Tang, and H. Fu, "Visualization of Voltage Stability Region of Bulk Power System", Proceedings of International Conference on Power System Technology PowerCon 2002, Vol. 3, 2002, pp. 1665-1668.
- [81] M. A. Pai, "Power System Stability", Amsterdam, The Netherlands: North Holland, 1981.
- [82] Y. Zeng and Y. Yu, "A Practical Direct Method for Determining Dynamic Security Regions of Electrical Power Systems", Proceedings of the International Conference on Power System Technology PowerCon 2002, Vol. 2, 2002, pp. 1270-1274.
- [83] I. A. Hiskens and R. J. Davy, "Exploring the Power Flow Solution Space Boundary", IEEE Transactions on Power Systems, Vol. 16, No. 3, August 2001.
- [84] Y.V. Makarov, V.A. Maslennikov, and D.J. Hill, "Calculation of Oscillatory Stability Margins in the Space of Power System Controlled Parameters", Proc. of the International Symposium

on Electric Power Engineering Stockholm Power Tech, Vol. Power Systems, Stockholm, Sweden, June 1995, pp. 416-422.

- [85] Y. V. Makarov and I. A. Hiskens, "A continuation method approach to finding the closest saddle node bifurcation point", Proceedings of the NSF/ECC Workshop on Bulk Power System Voltage Phenomena III, Davos, Switzerland, August 1994. Published by ECC Inc., Fairfax, Virginia.
- [86] K. Huang and H. Yee, "Improved Tangent Hyperplane Method for Transient Stability Studies", Proceedings of the International Conference on Advances in Power System Control APSCOM-91, Vol. 1, 5-8 November, 1991, pp. 363 – 366.
- [87] M. Djukanovic, D. J. Sobajic, and Y.-H. Pao, "Learning Tangent Hypersurfaces for Fast Assessment of Transient Stability, Proceedings of the Second International Forum on Applications of Neural Networks to Power Systems ANNPS '93, 19-22 April 1993, pp. 124 – 129.
- [88] Y. Yu, Y. Zeng, C. Huang, S. T. Lee, and P. Zhang, "A Practical Direct Method for Determining Dynamic Security Regions of Electrical Power Systems by Power Perturbation Analysis", International Conference on Electrical Engineering ICEE2004, July 4-8, 2004, Sapporo, Japan.
- [89] S. A. Sovalov and V. A. Semenov, Emergency Control in Power Systems, Energoatomizdat, Moscow, 1988 – in Russian.
- [90] M. A. El-Sharkawi, R. J. Marks, M. E. Aggoune, D. C. Park, M. J. Damborg, and L. E. Atlas, "Dynamic Security Assessment of Power Systems Using Back Error Propagation Artificial Neuron Networks," Proceedings of the 2nd Symposium on Expert System Applications to Power Systems, Seattle, WA, July 1989.
- [91] R. Kumar, A. Ipahchi, V. Brandwajan, M. A. El-Sharkawi, and G. Cauley, "Neuron Networks for Dynamic Security Assessment of Large Scale Power Systems: Requirements Overview," Proceedings of 1st International Forum on Applications of Neuron Networks to Power Systems, Seattle, WA, July 1991, pp. 65-71.
- [92] A.A. El-Keib and X. Ma, "Application of Artificial Neural Networks in Voltage Stability Assessment," IEEE Transactions on Power System, Vol. 10, No.4, Nov. 1995, pp. 1890-1896.
- [93] S. Chauhan and M.P. Dava, "Kohonen Neural Network Classifier for Voltage Collapse Margin Estimation," Electric Machines and Power Systems, Vol. 25, No. 6, July 1997, pp. 607-619.
- [94] Y. Mansour, A. Y. Chang, J. Tamby, E. Vaahedi, B. R. Corns, and M. A. El-Sharkawi, "Large Scale Dynamic Security Screening and Ranking Using Neuron Networks," IEEE Transactions on Power Systems, Vol. 12, No. 2, May 1997, pp. 954-960.
- [95] H B Wan and Y H Song, "Hybrid Supervised and Unsupervised Neural Network Approach to Voltage Stability Analysis", Electric Power System Research, Vol. 47, No. 2, 1998, pp.115-122.
- [96] V. R. Dinavahi and S. C. Srivastava, "ANN Based Voltage Stability Margin Prediction", IEEE Power Engineering Society Summer Meeting 2001, Vol. 2, 15-19 July 2001, pp. 1275-1280.
- [97] A. Sittithumwat and K. Tomsovic, "Dynamic Security Margin Estimation Using Artificial Neural Networks", IEEE Power Engineering Society Summer Meeting 2002, Vol. 3, 2002, pp. 1322-1327.
- [98] M. M. Salamaa, E. M. Saieda, M. M. Abou-Elsaada, and E. F. Gharianyb, "Estimating the Voltage Collapse Proximity Indicator Using Artificial Neural Network", Energy Conversion and Management, Vol. 42, No. 1, January 2001, pp. 69-79.
- [99] H. Hakim, "Application of Pattern Recognition in Transient Security Assessment," Journal of Electrical Machines and Power Systems, Vol. 20, 1992, pp. 1-15.

- [100] L. Wehenkel, Automatic Learning Techniques in Power Systems, Kluwer Academic Publishers, MA, 1998.
- [101] C. Aldea and S. C. Savulescu, "Evaluation of the Stability Reserve of Transelectrica's Transmission System by Using Quickstab Professional", WEC Regional Energy Forum – FOREN 2004, Neptun, 13-17 June 2004.
- [102] P. Dimo, "L'Analyse Nodale des Réseaux D'Énergie", Eyrolles, 1971.
- [103] T. Van Cutsem, C. Vournas, "Voltage Stability of Electric Power Systems", Kluwer Academic Publishers (Power Electronics and Power Systems Series), Boston, 1998.
- [104] T. Van Cutsem and R. Mailhot, "Validation of a Fast Voltage Stability Analysis Method on the Hydro-Quebec System", IEEE Transactions on Power Systems, Vol. 12, No. 1, February 1997.
- [105] F. Paganini, B.C. Lesieutre, "Generic Properties, One-Parameter Deformations, and The BCU Method", IEEE Transactions On Circuits And Systems I: Fundamental Theory And Applications", Vol. 46, No. 6, pp. 760-763, June 1999.
- [106] H.-D. Chiang, C.-C. Chu, and G. Cauley, "Direct Stability Analysis of Electric Power Systems Using Energy Functions: Theory, Applications, and Perspective", Proceedings of the IEEE, 13, 1995, pp. 1497-1529.
- [107] H.-D. Chiang, C.-S. Wang, and H. Li, "Development of BCU classifiers for on-line dynamic contingency screening of electric power systems", IEEE Transactions on Power Systems, 14, 1999, pp. 660-666.
- [108] Y. V. Makarov, Z.-Y. Dong, and D. J. Hill, "A General Method for Small Signal Stability Analysis", IEEE Transactions on Power Systems, Vol. 13, Issue 3, August 1998, pp. 979 – 985.
- [109] Z.-Y. Dong, Y.V. Makarov, and D.J. Hill, "Genetic Algorithms in Power System Small Signal Stability Analysis", Fourth International Conference on Advances in Power System Control, Operation and Management APSCOM-97, Vol. 1, November 11-14, 1997, pp. 342 - 347 (Conference Publication No. 450).
- [110] A.A. Fouad and V. Vittal, Power System Transient Stability Analysis Using the Transient Energy Function Method, Prentice Hall, 1991.
- [111] I. Dobson, "Computing a Closest Bifurcation Instability in Multidimensional Parameter Space", Journal of Nonlinear Science, Vol. 3, 1993, pp. 307-327.
- [112] Y.V. Makarov, V. A. Maslennikov, and D. J. Hill, "Calculation of Oscillatory Stability Margins in the Space of Power System Controlled Parameters", Proc. International Symposium on Electric Power Engineering Stockholm Power Tech: Power Systems, Stockholm, Sweden, 18-22 June, 1995, pp. 416-422.
- [113] Y. V. Makarov, D. J. Hill, and Z.-Y. Dong, "Computation of Bifurcation Boundaries for Power Systems: A New Δ -Plane Method", IEEE Transactions on Circuits and Systems I: Fundamental Theory and Applications, Vol. 47, Issue 4, April 2000, pp. 536 – 544.
- [114] Y.V. Makarov, D. J. Hill, and I. A. Hiskens, "Properties of Quadratic Equations and Their Application to Power System Analysis", Electrical Power and Energy Systems, 22 (2000), pp. 313-323.
- [115] M. Fulczyk and M. Sobierajski, "Probabilistic assessment of power system voltage stability margin using P-Q curve", Proc. 8th International Conference on Probabilistic Methods Applied to Power Systems PSCE'2004, Iowa State University, Ames, Iowa, September 2004.
- [116] "Voltage Stability/Security Assessment and On-Line Control", EPRI technical report TR-101931-V1-4, Vol. 1-4, 1993.

- [117] "Voltage Stability Analysis Program (VSTAB)", Version 2.1, User's Manual, EPRI Research ProjectRP30400-01, August 1992.
- [118] Xiaokang Xu, M. W. Gustafson, B.P Lam, J. D. Mountford., and S. L. Johnson, "Assessment of Voltage Stability and Real and Reactive Margins Using Advanced Analytical Tools", Proceedings of International Conference on Power System Technology PowerCon 2002, Vol. 4, 2002, pp. 2047 – 2051.
- [119] "VSAT – Voltage Security Assessment Tool", Available online: http://www.dsapowertools.com/downloads/VSAT_Brochure.pdf.
- [120] "PowerWorld Simulator – PVQV", Available online: <http://www.powerworld.com/products/pvqv.asp>.
- [121] S. Lockwood, R. Navarro, E. Bajrektarevic, P. Burke, S. Kang, P. Ferron, V. Kotecha, S. Kolluri, M. Nagle, S. Lee, P. Zhang, S. K. Agarwal, M. Papic, J. Useldinger, P. C. Patro, L. Arnold, D. Osborn, L. Fan, L. Hopkins, Member, M. Y. Vaiman, and M. M. Vaiman, "Utility Experience Computing Physical and Operational Margins: Part I – Basic Concept and Evaluation", 2004 IEEE PES Power Systems Conference & Exposition, New York, NY, October 10 - 13, 2004.
- [122] S. Lockwood, R. Navarro, E. Bajrektarevic, P. Burke, S. Kang, P. Ferron, V. Kotecha, S. Kolluri, M. Nagle, S. Lee, P. Zhang, S. K. Agarwal, M. Papic, J. Useldinger, P. C. Patro, L. Arnold, D. Osborn, L. Fan, L. Hopkins, Member, M. Y. Vaiman, and M. M. Vaiman, "Utility Experience Computing Physical and Operational Margins: Part II – Application to Power System Studies", 2004 IEEE PES Power Systems Conference & Exposition, New York, NY, October 10 - 13, 2004.
- [123] "BOR-Transient Stability: Dynamic Security Region", Available online: <http://www.vrenergy.com/docs/bor-ts.pdf>
- [124] M. Papic, M. Y. Vaiman, and M. M. Vaiman, "Determining a Secure Region of Operation for Idaho Power Company", IEEE Power Engineering Society General Meeting, June 12-16, 2005, pp. 2720 – 2725.
- [125] "NEPLAN Electricity - Voltage Stability", Available online: http://www.neplan.ch/sites/en/neplan_elec_calcmo_d_voltage_stability.asp.
- [126] "CYMVSTAB, Voltage Stability", Available online: <http://www.cyme.com/software/cymvstab/>.
- [127] C.D. Vournas, "Interruptible Load as a Competitor to Local Generation for Preserving Voltage Security", Available online: http://www.transmission.bpa.gov/orgs/opi/power_stability/DirLdContVournas.pdf.
- [128] "On-Line Application of DSATools", Available online: http://www.dsapowertools.com/html/prod_application.php
- [129] "POM - Real Time (POM-RT)", Available online: <http://www.vrenergy.com/pom-rt.htm>.
- [130] E. Hnyilicza, S. T. Y. Lee, F. C. Schweppe, "Steady-State Security Regions: Set-Theoretic Approach," Proceedings of the IEEE PICA Conference, pp. 347-355, 1975.
- [131] S. T. Lee, "Community activity room as a new tool for transmission operation and planning under a competitive power market", IEEE Bologna Power Tech Conference Proceedings, Vol. 4, 23-26 June, 2003.
- [132] "QuickStab at a Glance", Available online: http://www.eciqs.com/QuickStab_at_a_Glance.htm.
- [133] T. Van Cutsem, F. Capitanescu, C. Moors, D. Lefebvre, V. Sermanson, "An Advanced Tool for Preventive Voltage Security Assessment", Proc. 7th Symposium of Specialists in Electric Operational and Expansion Planning (SEPOPE), Curitiba (Brazil), May 2000.